

**AN
EXCHANGE
WITH
SOL
LEWITT**

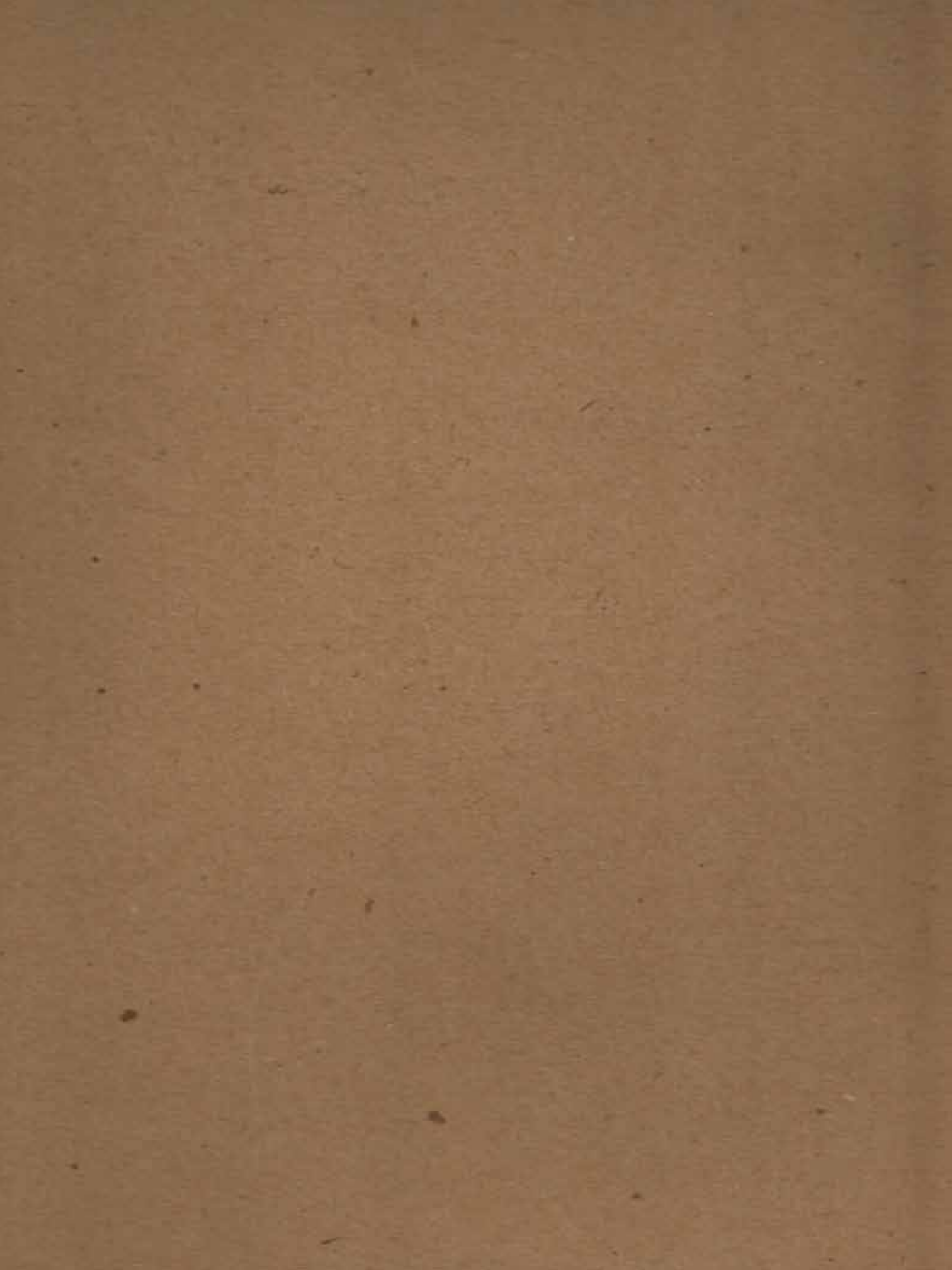

AN EXCHANGE WITH SOL LEWITT

A CURATORIAL PROJECT BY
REGINE BASHA

PRESENTED CONCURRENTLY BY
CABINET MAGAZINE
AND
MASS MOCA

PUBLICATION DESIGN BY
SUSAN BOWMAN



PHOTO: NICOLAS GULLOTTA

An Exchange With Sol LeWitt
A curatorial project by Regine Basha

MASS MoCA
22 January – 31 March 2011

Cabinet
20 January – 5 March 2011

CALL FOR SUBMISSIONS

This is a call to those who share an affinity with Sol LeWitt's legacy as a conceptual artist, to those who knew him and those who did not—to anyone who has ever wondered, "What would Sol LeWitt like?"

Your gift to Sol LeWitt can take the form of an image, an object, a piece of music, or a film. Books, ephemera, and other non-perishable items (e.g. wine) are also welcome. Other ideas may be discussed with the curator. 2D contributions should be no larger than 8.5 x 11 inches; 3D contributions should be no larger than 12 x 12 x 12 inches.

All contributions will be exhibited at either Cabinet or MASS MoCA. Please note that we cannot return your contribution. You can, however, pick it up at the end of the exhibition if prior arrangements have been made.

Published by Cabinet Books and
MASS MoCA. A curatorial project
by Regine Basha

Coordinated by: Joshua Bauchner,
Anya Kaplan-Seem, Claire Lehmann

Design: Susan Bowman
Photography: Jaime Permuth
and Hyong ROUNG MIN

Special Thanks to: Susan Bowman, Mike
Chesser, Rachel Gugelberger, Carol LeWitt,
Denise Markonish, Janet Passehl, Jaime
Permuth, Sal Randolph, Hyong ROUNG MIN,
and Lauren van Haafden-Schick.

ISBN # 978-1-932698-52-7

Printed by Linco Press

Copyright: Regine Basha, Cabinet,
and MASS MoCA, 2011

ENTERING THE CONVERSATION

REGINE BASHA

Art is a gift ...

*To speak of
brotherhood
as the first law
does is to affirm
a trust in the
circulation of
the gift.'*

This is an exhibition about Sol LeWitt and not about Sol LeWitt. Whether or not it is even a curated exhibition is an open question. In fact, the open-call model I chose for it is a challenge and a risk to the curatorial process; open calls are messy, unwieldy, and arbitrary. But given Sol LeWitt's practice of responding to each and every artwork he received — even those from total strangers — with an artwork of his own, it seemed that an open call would be not only appropriate but symbolically meaningful. I was pleased that Cabinet and MASS MoCA shared my view that this approach was right for the project: it would be our challenge to accept the hundreds of works that would come in for the exhibition, just as LeWitt himself had done so diligently in his own exchanges.

Within the given one-month submission window, Cabinet received what might be called a "flash mob" of contributions via mail, email, and in-person drop-offs. Since the call was announced in *Cabinet* magazine no. 37 and through e-flux (as well as sent to LeWitt's friends and colleagues), responses came from around the globe. Drawings, paintings, sculptures, poems, memento mori, videos, books, photographs, soundworks, postcards, letters, musical scores, recipes, instructional works, food, drink, clothing, quotes, stories,



performances, and other indescribable items arrived and all had to be catalogued and documented.

In most cases, the guidelines were met; in other cases, they were somewhat "negotiated." By the end, we had amassed what could be called a LeWittian collection of curiosities, an idiosyncratic temporary archive, or simply a portrait of the artist through his fans. Despite the fact that we were not officially exchanging anything (except for a copy of this publication), submissions poured in, full of heartfelt thanks and anecdotes recalling encounters with LeWitt both intimate and accidental. Is any other conceptual artist so deeply beloved?

A visit to Sol LeWitt's private collection inspired the somewhat "irrational thought"² that ultimately led to the show. Janet Passehl, the collection's longtime curator, showed me a slide presentation of works in the collection, many of which were acquired through exchange. What was most striking was the range of work; I witnessed high conceptual art alongside amateur and folk paintings, a clear testament to the ethos of generosity to which LeWitt remained committed over the course of his long and productive career. Passehl's comment that "it's interesting to see what people thought Sol LeWitt would like" stayed

with me for a long time. I began to consider posing that question as a discursive, curatorial premise. It's possible that the germ of this project actually goes back more than ten years, when a graduate advisor told me in response to my thesis on drawing: "You have to deal with Sol LeWitt." Given the monumentality of the artist's body of work, how exactly do you "deal with" him? This project allowed me to enter a conversation around the culture of Sol LeWitt through what one might call the minor histories that intersect with it. I did not want to create a sentimental homage to the artist as much as to create an exercise for and of the artist — one that engaged with his work and modus operandi as an artist more fully than any statement about it would. For this reason, it could not be curated in any conventional sense; it could only be set into motion.

As the collection of objects and ephemera accrued, a number of themes endemic to LeWitt's practice rose to the surface. His relationship with Eva Hesse was honored in a number of works (Annie Farrar, Cedar Tavern Singers, Maritza Ruiz Kim); the early "Sentences on Conceptual Art" were reconsidered (Luis Camnitzer, David Schafer, Mauricio Limon); and instructional drawings and diagrammatic schemes also featured (Seth Cluett, Rose Shakinovsky, Lucy Lippard, Clement Valla). The show included musical scores inspired by his drawings (Manuel Sosa, Steve Roden, Walter Hekster); collections of books, poetic indexes and books with odd lists (Dan Levenson, Bruce Altshuler, Ian MacTilstra, Pablo Helguera and Jeff Eaton, Hyo Myoung Kim, Craig Leonard, Sal Randolph); and works that engaged with performance (Stephanie Diamond & Adia Millett, Hope Ginsburg, Kanji Ouellette) and with LeWitt's murals (Max Goldfarb & Alyson Strafella, Teresita Fernandez). Some of the more eccentric contributions included a wisdom tooth from Joelle Nadeau; a stuffed animal from David Ingenthron that had once been a crew mascot during the creation of a LeWitt mural; and Hope Sandrow's Hudson Valley chicken coop based on a LeWitt parallelogram.

And of course dozens and dozens of works recalled the obsessive repetitive lines and cubes for which LeWitt is best known. To our great pleasure, we also received submissions by entire art classes that took on this project as an assignment, including groups from New York's School of Visual Arts; the University of Georgia; the Rhode Island School of Design; a school in Porto Alegre, Brazil, and even an elementary school from LeWitt's hometown of Chester, Connecticut. There were also countless mailed postcards and letters — some even addressed to LeWitt directly.

In short, entirely different art worlds came together, generations mingled, and vastly conflicting styles and aesthetic disciplines blurred at the edges. It was as if a parallel, democratic art world had formed, with LeWitt its absent — yet still vibrant — center.

1. Lewis Hyde, *The Gift*, pp. xvi, 149.
2. "Irrational thoughts should be followed absolutely and logically." Sentence #5 from "Sentences on Conceptual Art" by Sol LeWitt. First published in 0-9 (New York, 1969).

AN EXCHANGE WITH SOL LEWITT INDEX

Call For Contributions	2
Introduction: <i>Entering the Conversation,</i> by Regine Basha	3-4
Images of all contributions <i>(in alphabetical order)</i>	5-188
Directory of all contributing artists	188-192

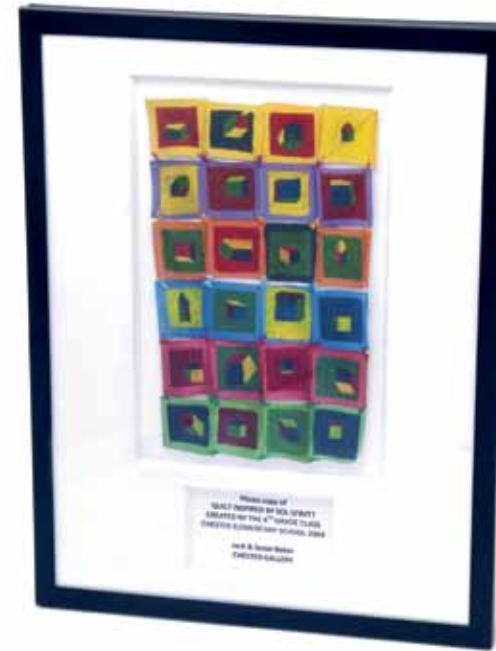

4th Grade Class, Chester Elementary School
Quilt Inspired by Sol LeWitt

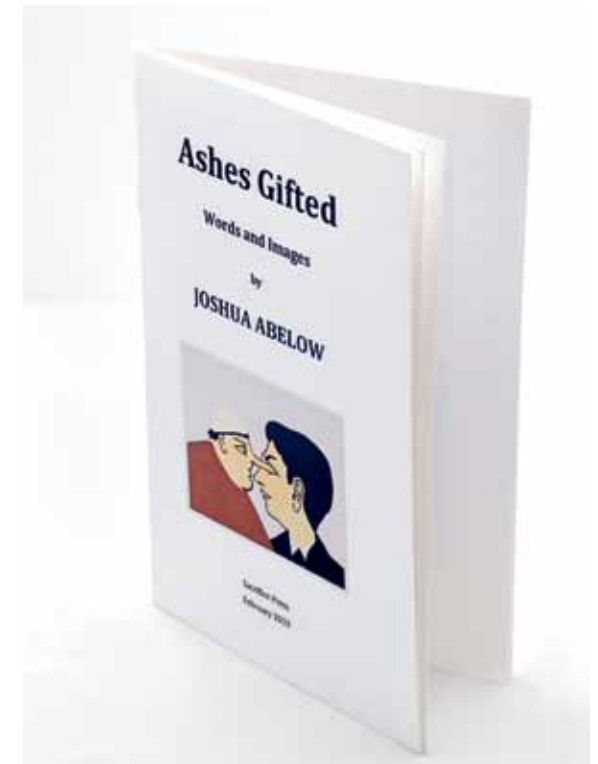

Joshua Abelow
Ashes Gifted



Tisch Abelow
Untitled



Edith Abeyta
Death Rattle

W
i
l



Alexis Acquista
For Sol LeWitt



Aeolian Recreational Boundary Institute
19 Miles



Francine K. Affourtit
For Sol LeWitt



Lisa Adamucci
Eat a Peach



Isaac Aden
Two



June Ahrens
Gift for Sol



Rachel Ake
After Sol LeWitt, Wall Drawing 821



Beatriz Albuquerque
no title



Simon Aldridge
Culture Is What Sets Our Company Apart



Can Altay, Jonathan Mosley & Sophie Warren
no title



Bruce Altshuler
Discussion of Sol LeWitt in "Art by Instruction and the Pre-History of do it," do it, exh. cat. (New York: Independent Curators International, 1997) (for Sol)

anonymous fabrication implies a distance between the artist and the realized artwork. The role of the artist is thus transformed from maker to connector. This connection between Minimalism and conceptualism was made clear by Sol LeWitt in his important "Paragraph on Conceptual Art," published in June 1967 in *Artforum*. Here LeWitt outlined ideas rather than their physical manifestation, and he accepted unrealized concepts as works in their own right. And as concepts became the focus their linguistic expression was admitted as an artistic form. Artworks could be included in statements, and a collection of statements could constitute an exhibition.

The move from conceptual work to conceptual exhibition was made by dealer/publisher/organizer Seth Siegelaub in his exhibition Douglas Huebner: November, 1968. Lacking an exhibition space, Siegelaub presented Huebner's show in the form of a catalog alone. Huebner's pieces—open time constructions impossible to see at any one time or place—appeared in verbal descriptions, maps and other documentation. The next month Siegelaub published Lawrence Weiner: Dimension, not explicitly introduced as an exhibition but clearly functioning that way. Weiner's works were presented in written form—"The minutes of open joint directly upon the floor from a standard second grade" (fig. 4)—and they each specified a material process that could be carried out in the world. (Whether his instructions ever were carried out, whether the wall actually was physically realized, was a matter of indifference to Weiner, who left that decision to the "viewer.") In January 1969 Siegelaub mounted his most famous exhibition in an unused office at East 12nd Street in New York, not even here the catalog was fundamental. For while the exhibition known as The January Show displayed in physical space pieces by Robert Barry, Douglas Huebner, Joseph Kosuth and Lawrence Weiner, Siegelaub insisted that the catalog was primary: "The exhibition consists of the ideas communicated by the catalog; the physical process (or the work) is supplementary to the catalog."¹⁴

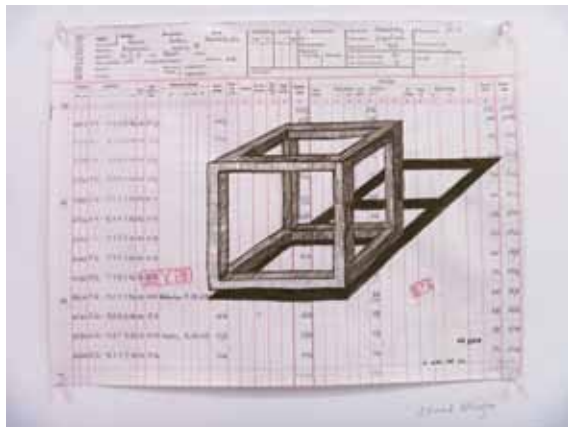

Edward Allington
A Cube for Sol



Matt Allison, Shawn Henrie & Margan Kendall
Sugar Dissolves Process...



Phil Amrhein
no title

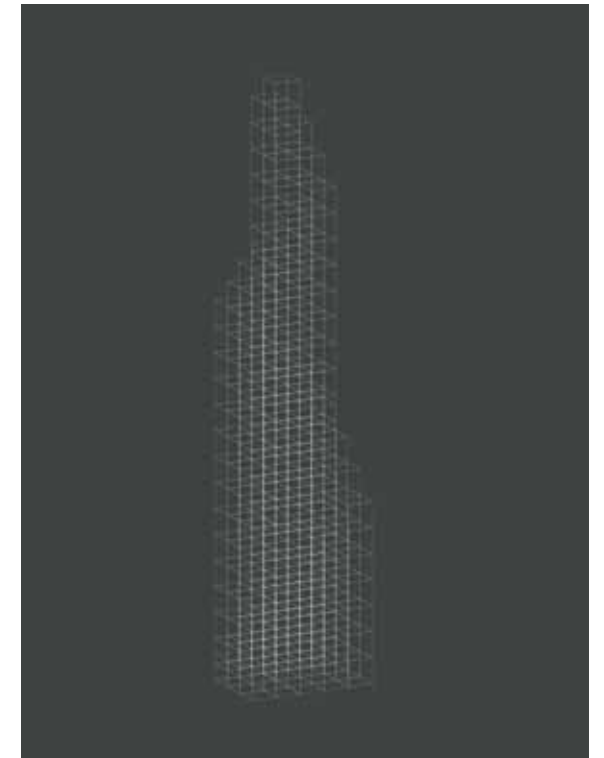

Karl Anderson
Companion to 24C



Patrick Anderson-McQuoid
Flow

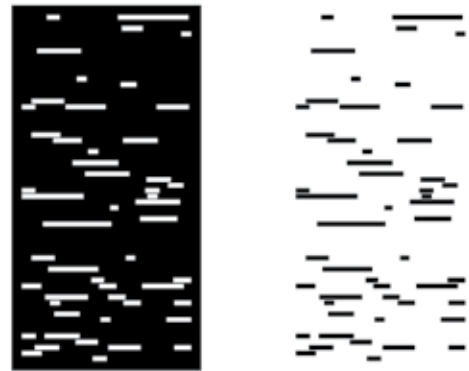

Huw Andrews
This Is What I Did

I need this sentence for something else /
Just think of another one then
This one could move /
This one can't
This is an exercise /
Just something to do
I really like this /
Yeah, but its not as good as the other two
What's this white bit for /
Its what the forward slash means
(Actually, it just looks better like this)

Ik moest naar een brieven-
bus lopen om deze kaart te
versturen,

I had to walk to a post box
to send this postcard,

Marijke Appelman
no title



Michael Arata
"Soul"



Anonymous
International Strike of Artists 1979



Anonymous
Dear Sol, a message from the future...



David J. Armacost
Untitled



Holly Armishaw
Pharmacology

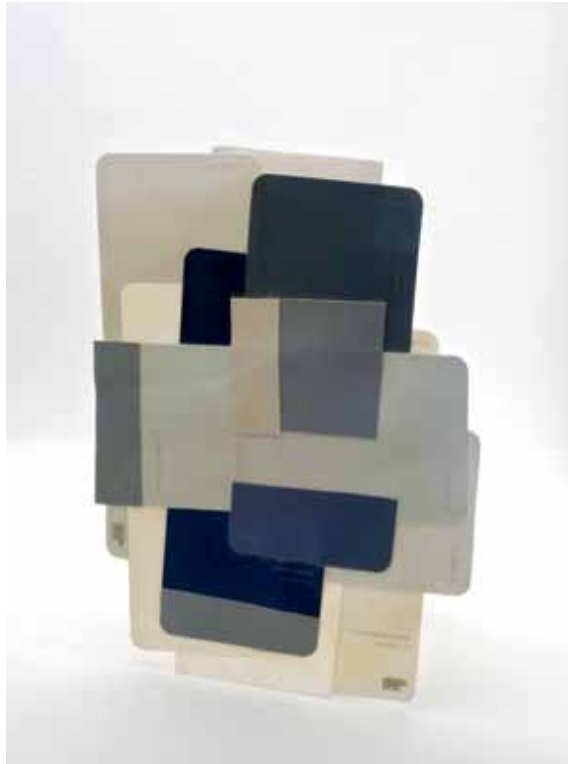

Diana Arvanites
no title



Judy Asbury
no title



Christian Awe
Gift from Berlin



Nina Lola Bachhuber
Untitled



Shinsuke Aso
no title



Carla Asperilla
After Sol LeWitt Wall Drawing 439

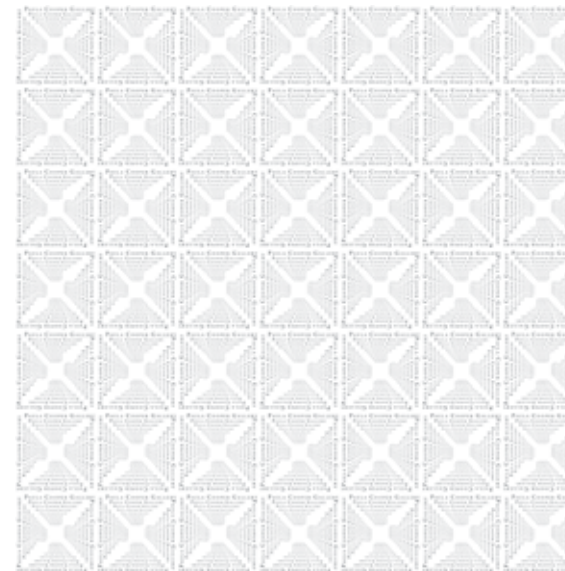

Fia Backström
Tablecloth

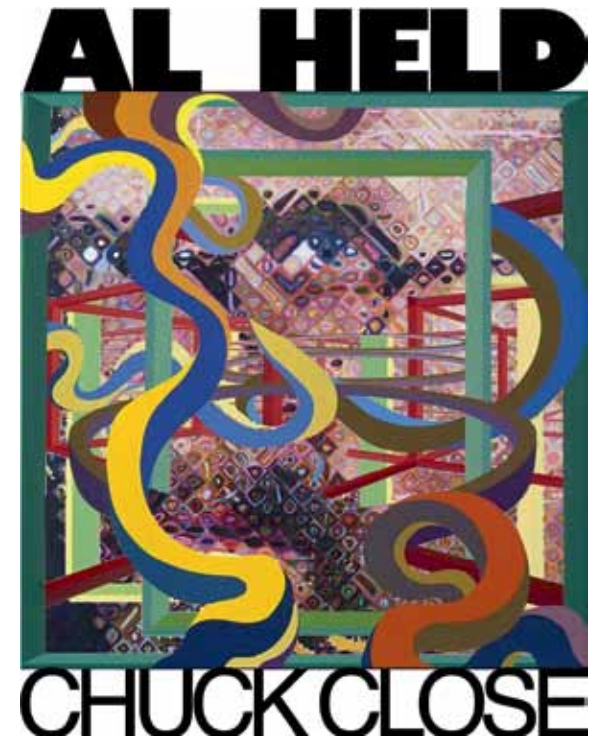

Karl Baden
no title



Saebom Bae
After Sol LeWitt, Wall Drawing 415D



Alisha Baird
Detrifaction

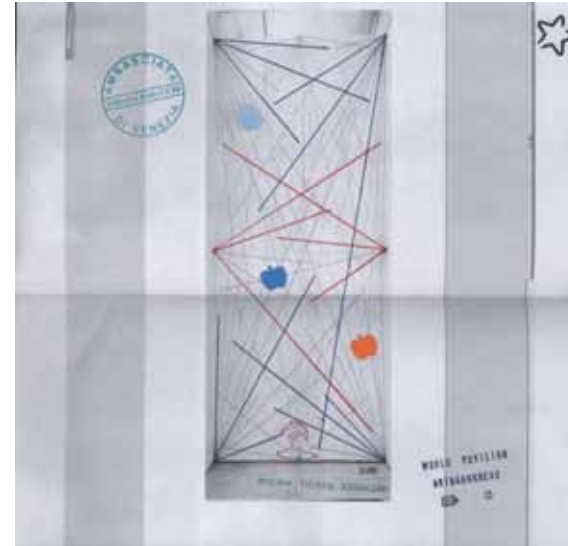

Tiziana Baracchi
Tarantino Mail Art



Kumasi J. Barnett
D#3 (As Yet Untitled)



Steven Ball
Ann & Pat



Victor Ballesteros
Two Finches



Rita Barros
White Frame



Louise Barry
1. to talk to god



Amy Bassin
Out of the Darkness

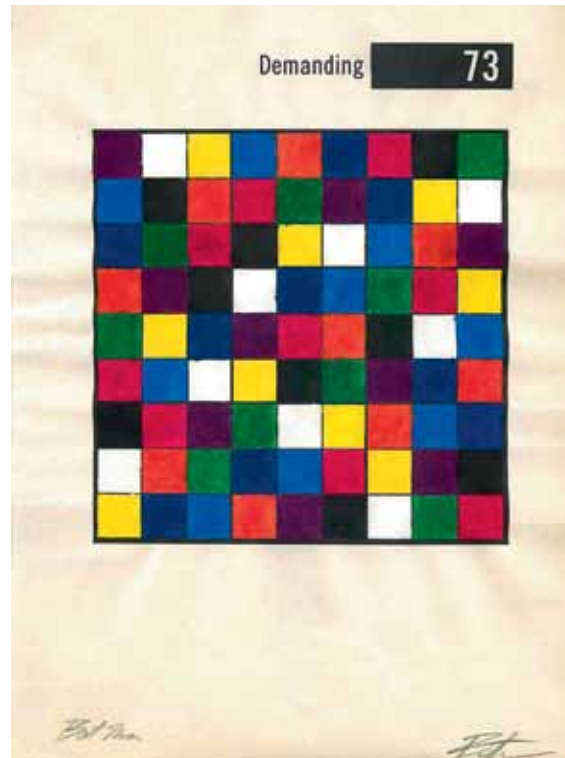

Batman & Batman
Demanding 73

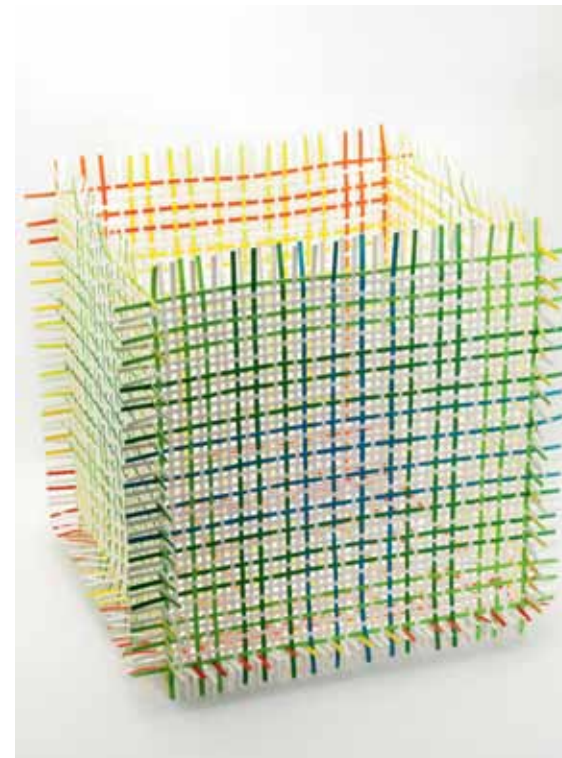

Joell Baxter
Drawing for Sol LeWitt



Matthew Beall
no title



David Baumflek
Dark Matter, My Love



Matthew Bax
Solace

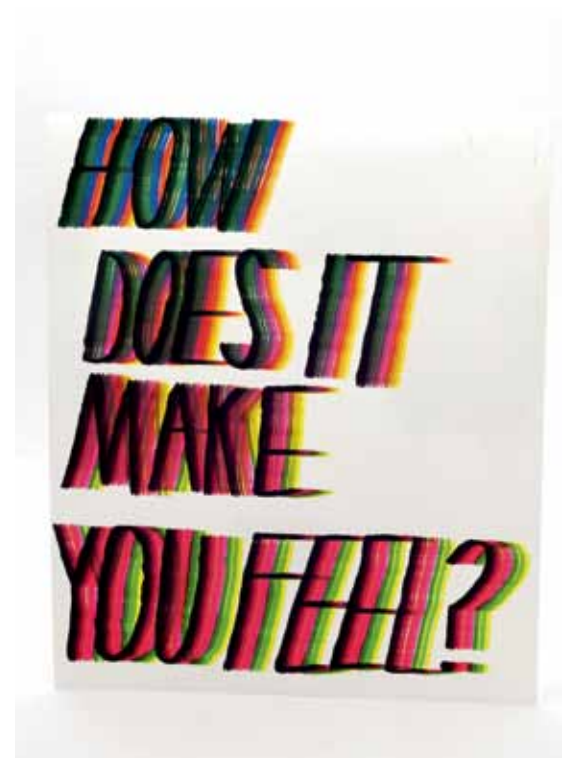

Richie Bearden
How Does It Make You Feel



Tinka Bechert
no title



Hilary Berseth
5 Electrochemical Samples

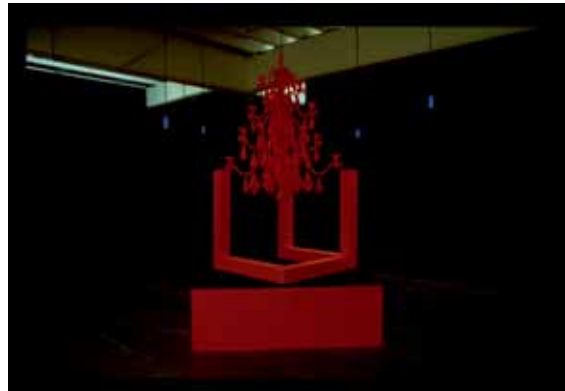

Damiano Bertoli
Frightened of This Thing That I've Become



Ana Bilankov
Landscape with Human Figure



Birds Are Nice
I Heart Sol LeWitt



Katrin Bertram
19th March 2008—Score of a Working Day



Gary A. Bibb
Nota Bene # 549



Mariella Bisson
Glowing Future ("Once a piece is done, I move on. I always think the next step will be much better than what I have done before — a chance for redemption, a hope I can erase the past and step into the glowing future." Sol LeWitt)



Tina Blackburn
Centered Marking



Josh Blackwell
Plastic Bag as a Humble Present



Alexandra Blaiotta
Fragmented Squares



Alicia Bonilla-Puig
no title



David Borawski
no title

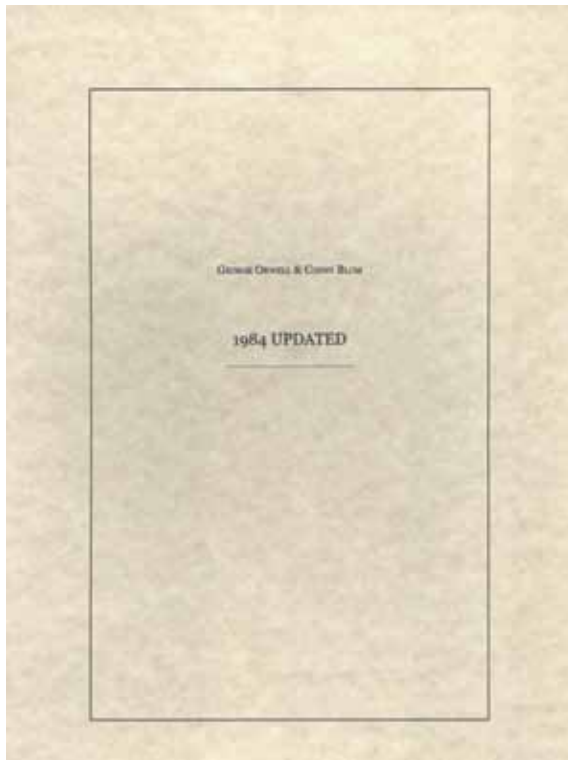

Conny Blom
1984, Updated

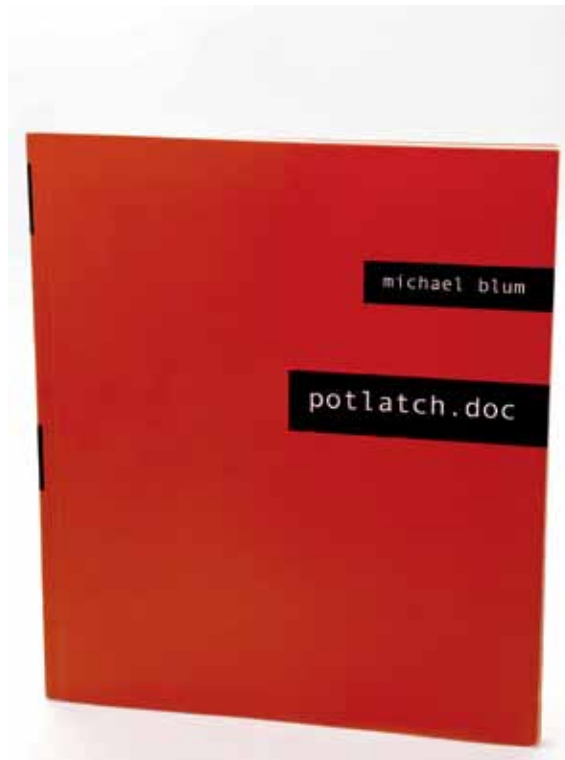

Michael Blum
Potlatch.doc



Dmitry Borshch
Wildbirds among Branches



Nathan Boyer
Enter the Dragon

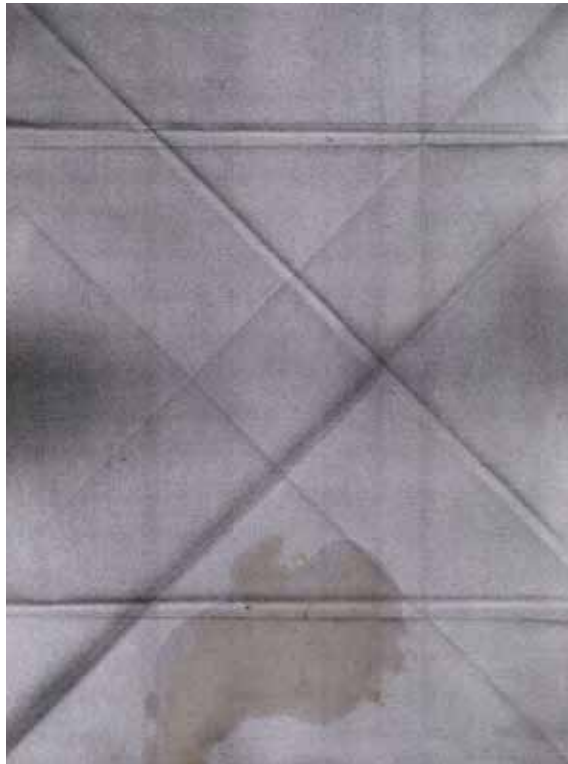

Daniel Bozhkov
Sol LeWitt/Creamy Almond Butter

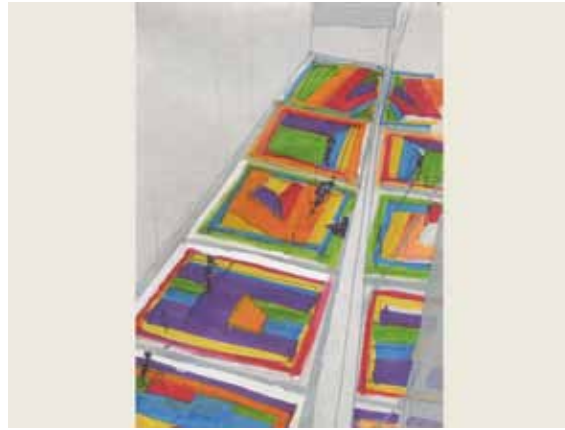

Nell Breyer
Bars of Color within Squares

Make your
point.
line
plane
volume
dimension
REALITY

Andre Brocatus
no title

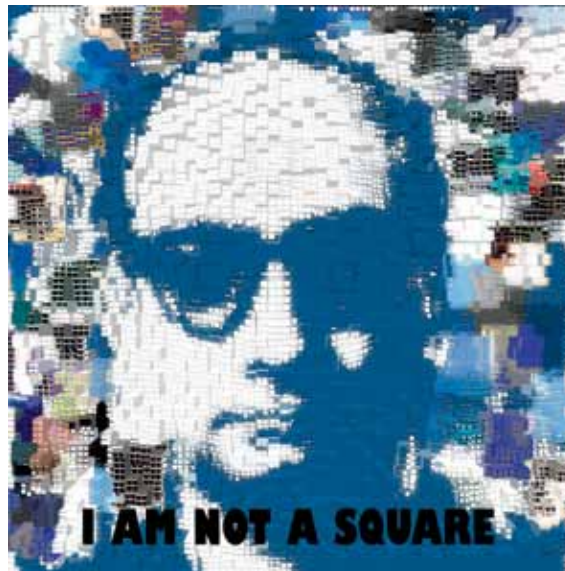

Collette Broeders
Sol LeWitt Squared

untitled (round)
for three to nine instruments

no sol lewitt

each musician enters independently on a note different from the others:
notes are played very slowly from left to right, with rests in between, looped as a kind of round, the musician ending on the note preceding the note on which he or she began

all notes are soft and simple, any octave, medium length (i.e., a breath or bow)

the process may occur up to nine times in movement performed as an ensemble, each musician beginning on a new note for each movement; some silence in between movements

Jason Brogan
2010

"The idea becomes a machine that makes the art. This kind of art is not theoretical or illustrative of theories; it is intuitive, it is involved with all types of mental processes and it is purposeless."
Sol LeWitt, Paragraph on Conceptual Art (1967)

Jason Brogan
Untitled (Round)



Adam Broomberg & Oliver Chanarin
Political I, Sheet 6, Parades



D. Matthew Brown & Kara Warren
Nastenka's Dress



Rae Broyles
Vision Exchange



Jo Brudenell
Memories Are Like Chinese Whispers

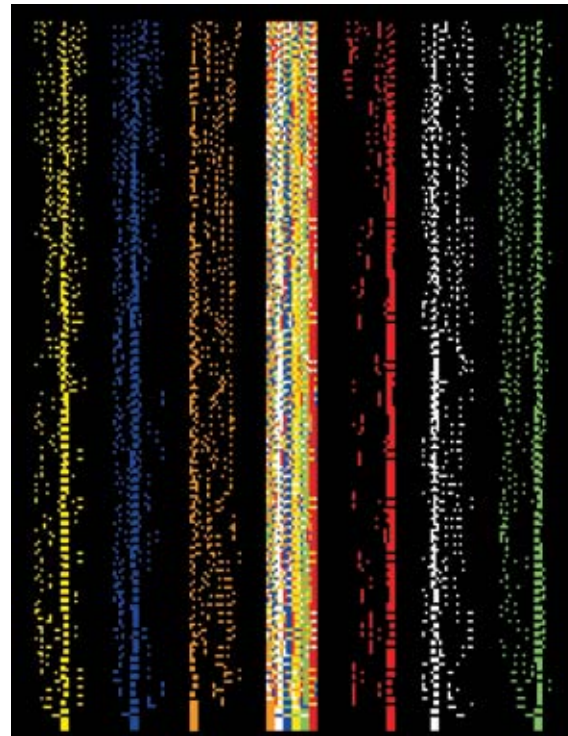

James C. Burns
Eighty-Two Steps



Kit Callahan
no title



Javier Cambre
From the Series Birds of Paradise

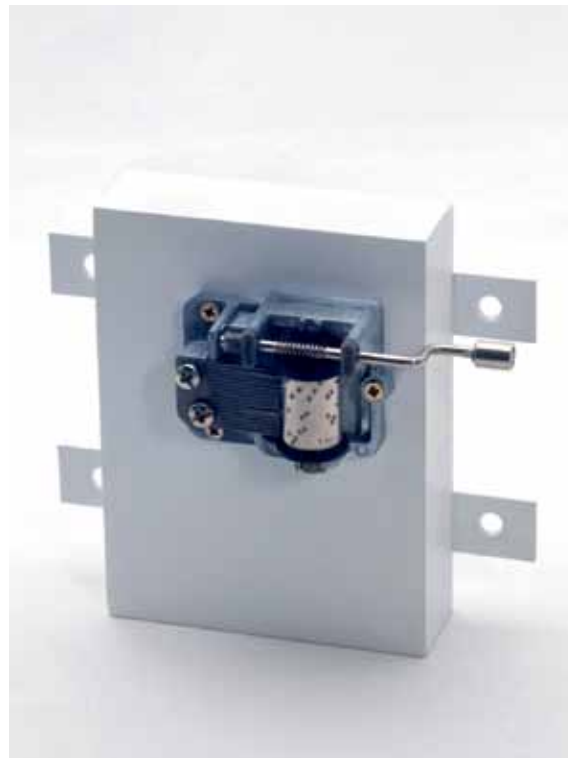

Bibi Calderaro
Please Wind Up



Luisa Caldwell
For Sol LeWitt

- SOL LEWITT REVISED**
1. Conceptualist artists expand the limits of knowledge. They keep to conclusions beyond these limits.
 2. Rational judgments repeat rational judgments.
 3. Irrational judgments expand and enrich rationality.
 4. Formal art deals with packaging.
 5. Irrational thoughts should be followed absolutely and logically. This generates new irrational thoughts, etc.
 6. If the artist changes his mind midway through the execution of the piece he compromises the result and repeats past results. Better to finish consistently and then throw it away.
 7. Artmaking is always in danger of being about ego. If so, it is personal therapy and otherwise useless.
 8. When words such as painting and sculpture are used, they constrict crafts and not art, thus placing limitations on the artist who would be reluctant to make art that goes beyond these limitations.
 9. The concept and idea are different. The former implies a general direction while the latter is the component. Ideas implement the concept.
 10. Ideas can be works of art; they are in a chain of development that may eventually find some form. All ideas need not be made physical.
 11. Ideas do not necessarily proceed in logical order. They may set one off in unexpected directions, but an idea must necessarily be completed somewhere before the next one is formed. Incompletion is a form of completion.
 12. For each work of art that becomes physical there are many more important variations that do not.
 13. A work of art may be understood as a conductor from the artist's mind to the viewer's, ideally it should also be understood as a conductor from the viewer's mind to the artist.
 14. The words of one artist to anybody else and from anybody else to the artist may induce an idea chain, even if they don't share the same concept.
 15. Since no form is intrinsically superior to another, the artist may use any form, from an expression of words (written or spoken) to physical reality, equally.
 16. If sentences are used, and they proceed from ideas about art and address them, then they are sentences on art.
 17. All ideas are art if they are so intended.
 18. One usually understands the art of the past by applying the convention of the present, thus archeologically misunderstanding and appreciating the art of the past. That makes all art contemporary.
 19. The conventions of art should be altered by subsequent works of art.
 20. Successful art changes our understanding of the conventions by altering our perceptions.
 21. Perception of ideas leads to new ideas.
 22. The artist cannot imagine his art, and cannot perceive it until it is complete.
 23. One artist may misperceive (understand differently from the artist) a work of art but still be set off in his own chain of thought by that miscomprehension.
 24. Perception is subjective.
 25. The artist may not necessarily understand his own art. His perception is neither better nor worse than that of others.
 26. An artist may perceive the art of others better than his own.
 27. The concept of a work of art may involve the matter of the piece and/or the process in which it is made as means of communication.
 28. Once the idea of the piece is established in the artist's mind and the final form is decided, the process is carried out blindly but not deafly. There are many side effects that the artist cannot imagine but which he should listen to. These may be used as ideas for remaking the work, discarding it, or for new works.
 29. The process is mechanical and should not be tampered with. It should run its course until there is critical distance.
 30. There are many elements involved in a work of art. The most important are the most obvious.
 31. If an artist uses the same form in a group of works, and changes the material, one would assume the artist's concept involved the material. Then the form should be revised.
 32. Banned ideas cannot be received by beautiful execution.
 33. It is difficult, but not impossible, to hough a good idea.
 34. When an artist learns his craft too well he becomes its servant, makes slick art, and amuses it.
 35. These sentences comment on comments about art, but are not art.

Luis Camnitzer
Sol LeWitt Revised



Arabella Campbell
9 Cubes Make a Square (for Sol LeWitt)



J. Lynn Campbell
To Be or Not to Be (#2)



Paulo Campos
After Sol LeWitt, Wall Drawing 439



Angela Caporaso
Millefili



Emily Cappa
Two Meandering Lines



Stacey Cann
Three Portraits of Sol LeWitt



Henrik Capetillo
1 Year is 1 Year



Kim Carlino
Meditation VI

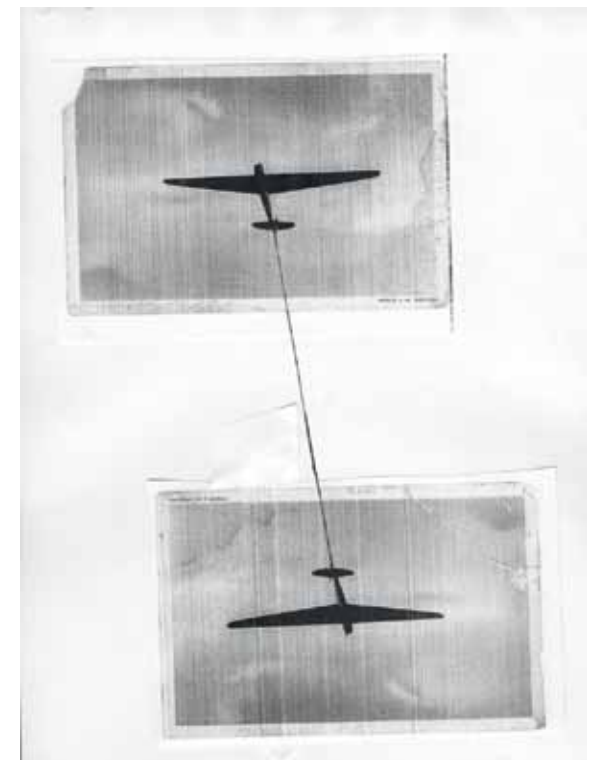

Antonia Carrara
It's Cool, We Can Still Be Friends



Laura Carton
To Sol with Love



Rose Marie Castoro
For Sol

```

inbetween_frames.py
# getting it ready to go into a script
# see http://www.pygame.org/wiki/pygameapi
# also see http://www.pygame.org/wiki/pygameapi
# and see http://www.pygame.org/wiki/pygameapi
# also see http://www.pygame.org/wiki/pygameapi

import sys
import pygame
import random
import time

pygame.init()
screen = pygame.display.set_mode((640, 480))
clock = pygame.time.Clock()

def main():
    # create a list of objects
    objects = []

    # create a new object
    obj = Object()
    obj.spawn()

    # add the object to the list
    objects.append(obj)

    # loop until the user presses q
    while True:
        for event in pygame.event.get():
            if event.type == pygame.QUIT:
                sys.exit()

        # update the objects
        for obj in objects:
            obj.update()

        # draw the objects
        screen.fill((0, 0, 0))
        for obj in objects:
            obj.draw(screen)

        # flip the screen
        pygame.display.flip()

        # tick the clock
        clock.tick(60)

    # clean up
    pygame.quit()

class Object:
    def __init__(self):
        self.x = random.randrange(0, 640)
        self.y = random.randrange(0, 480)
        self.size = random.randrange(10, 50)

    def spawn(self):
        self.x = random.randrange(0, 640)
        self.y = random.randrange(0, 480)
        self.size = random.randrange(10, 50)

    def update(self):
        pass

    def draw(self, screen):
        pygame.draw.circle(screen, (255, 255, 255), (self.x, self.y), self.size)
    
```

Jonathan Cecil & Yumi Kinoshita
Inbetween Frames

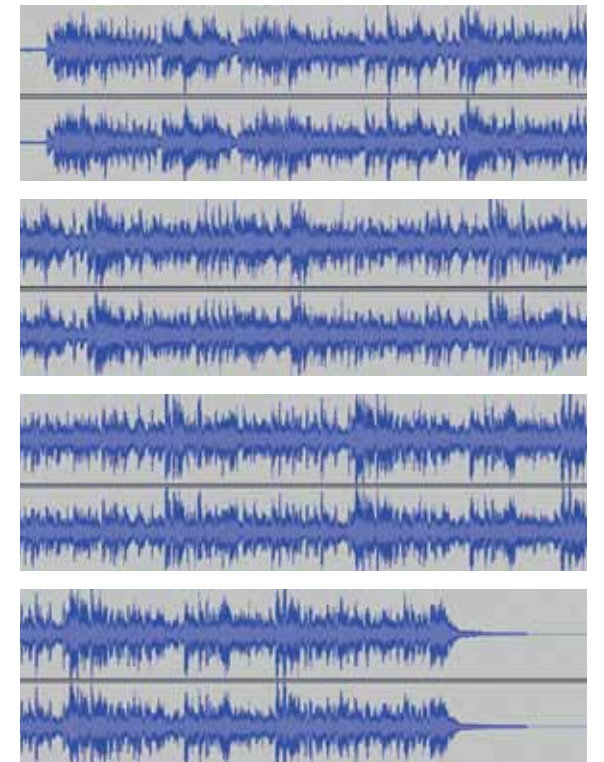

Cedar Tavern Singers
Dear Eva from Sol



Anibal Catalan
Morpho Mural Drawing



Michael Caudo
Fuck This Graph



Anna Ceeh
Verbal



Katherine Cercone
no title



Justin Abbott Chalew
Rainbow



Jenny Zhe Chang
Micro Disc



Marcy Chevali
no title



Andrea Chiesi
no title



Jessica Chen
After Sol LeWitt



Joanne Cheung
Light Insertions

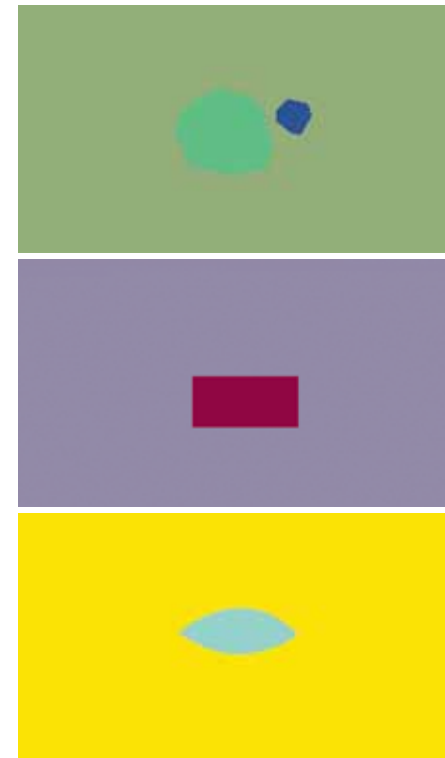

Nathalie Chikhi
The expressives, contemplatives



Helen Cho
Name Project for Eva Hesse

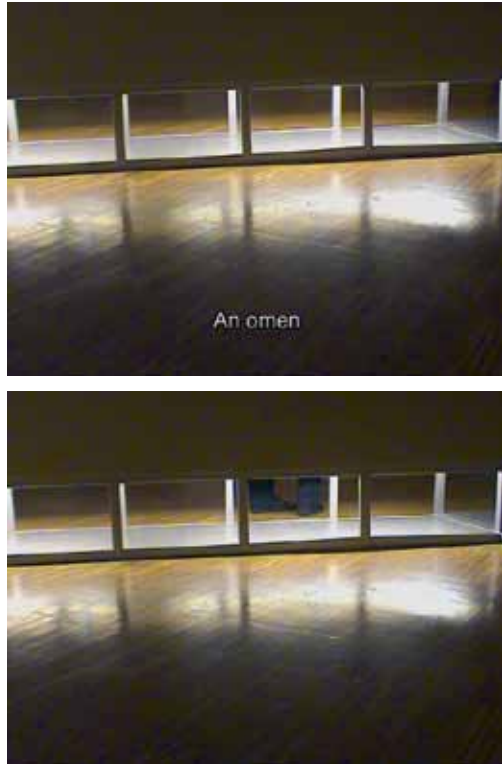

Constantinos Chondros
OIONOS (An Omen)



Warren Chong
no title



Karen Ciaramella
Evolving Conversation with Sol LeWitt



Gina Clark
Dumpy Hipper



Tony Yin Tak Chu
Paper Boat



Sarawut Chutiwongpeti
The Installation series of Untitled (Wishes, Lies and Dreams)



Hanna Clark
no title



Seth Cluett
100 circles to compare

11final.099.edit
99 songs, 8.4 hours, 695.9 MB

Name	Time	Album	Artist
1.01	0:00	1.01	1.01
1.02	0:00	1.02	1.02
1.03	0:00	1.03	1.03
1.04	0:00	1.04	1.04
1.05	0:00	1.05	1.05
1.06	0:00	1.06	1.06
1.07	0:00	1.07	1.07
1.08	0:00	1.08	1.08
1.09	0:00	1.09	1.09
1.10	0:00	1.10	1.10
1.11	0:00	1.11	1.11
1.12	0:00	1.12	1.12
1.13	0:00	1.13	1.13
1.14	0:00	1.14	1.14
1.15	0:00	1.15	1.15
1.16	0:00	1.16	1.16
1.17	0:00	1.17	1.17
1.18	0:00	1.18	1.18
1.19	0:00	1.19	1.19
1.20	0:00	1.20	1.20
1.21	0:00	1.21	1.21
1.22	0:00	1.22	1.22
1.23	0:00	1.23	1.23
1.24	0:00	1.24	1.24
1.25	0:00	1.25	1.25
1.26	0:00	1.26	1.26
1.27	0:00	1.27	1.27
1.28	0:00	1.28	1.28
1.29	0:00	1.29	1.29
1.30	0:00	1.30	1.30
1.31	0:00	1.31	1.31
1.32	0:00	1.32	1.32
1.33	0:00	1.33	1.33
1.34	0:00	1.34	1.34
1.35	0:00	1.35	1.35
1.36	0:00	1.36	1.36
1.37	0:00	1.37	1.37
1.38	0:00	1.38	1.38
1.39	0:00	1.39	1.39
1.40	0:00	1.40	1.40
1.41	0:00	1.41	1.41
1.42	0:00	1.42	1.42
1.43	0:00	1.43	1.43
1.44	0:00	1.44	1.44
1.45	0:00	1.45	1.45
1.46	0:00	1.46	1.46
1.47	0:00	1.47	1.47
1.48	0:00	1.48	1.48
1.49	0:00	1.49	1.49
1.50	0:00	1.50	1.50
1.51	0:00	1.51	1.51
1.52	0:00	1.52	1.52
1.53	0:00	1.53	1.53
1.54	0:00	1.54	1.54
1.55	0:00	1.55	1.55
1.56	0:00	1.56	1.56
1.57	0:00	1.57	1.57
1.58	0:00	1.58	1.58
1.59	0:00	1.59	1.59
1.60	0:00	1.60	1.60
1.61	0:00	1.61	1.61
1.62	0:00	1.62	1.62
1.63	0:00	1.63	1.63
1.64	0:00	1.64	1.64
1.65	0:00	1.65	1.65
1.66	0:00	1.66	1.66
1.67	0:00	1.67	1.67
1.68	0:00	1.68	1.68
1.69	0:00	1.69	1.69
1.70	0:00	1.70	1.70
1.71	0:00	1.71	1.71
1.72	0:00	1.72	1.72
1.73	0:00	1.73	1.73
1.74	0:00	1.74	1.74
1.75	0:00	1.75	1.75
1.76	0:00	1.76	1.76
1.77	0:00	1.77	1.77
1.78	0:00	1.78	1.78
1.79	0:00	1.79	1.79
1.80	0:00	1.80	1.80
1.81	0:00	1.81	1.81
1.82	0:00	1.82	1.82
1.83	0:00	1.83	1.83
1.84	0:00	1.84	1.84
1.85	0:00	1.85	1.85
1.86	0:00	1.86	1.86
1.87	0:00	1.87	1.87
1.88	0:00	1.88	1.88
1.89	0:00	1.89	1.89
1.90	0:00	1.90	1.90
1.91	0:00	1.91	1.91
1.92	0:00	1.92	1.92
1.93	0:00	1.93	1.93
1.94	0:00	1.94	1.94
1.95	0:00	1.95	1.95
1.96	0:00	1.96	1.96
1.97	0:00	1.97	1.97
1.98	0:00	1.98	1.98
1.99	0:00	1.99	1.99
2.00	0:00	2.00	2.00

Page 1 of 2

Tony Cokes
1!



Dan Collin
Dear Sol. Thanks for Everything. Peace



Carol Cooper
Somnambule



Paul Cope
Belstead Variation 1



Roberto Comini
All the best, Sol!



Brian Conery
Locations—Asteroid

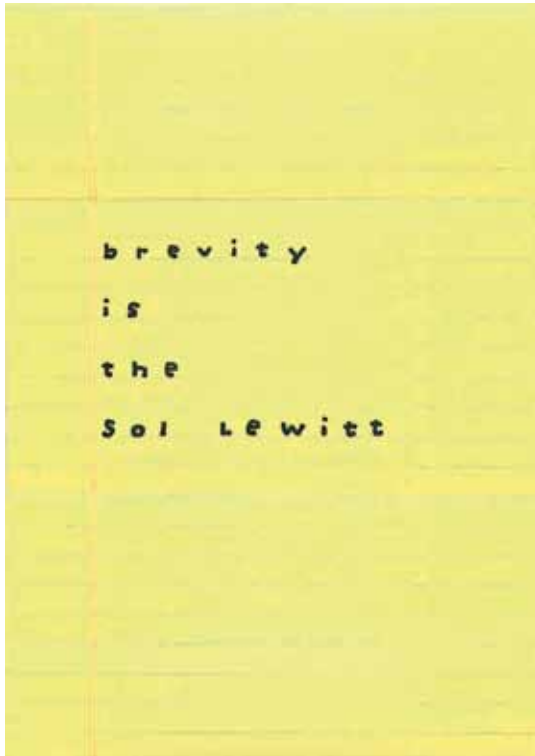

Lynn Corbett
no title



Annette Cords
Weave Draft for Sol LeWitt



Alice Cork
5 Preliminary Sketches of Utills



Norbert Costin
Black Mirror



Nicholas Aaron Cox
no title



Stephen Cox
Untitled

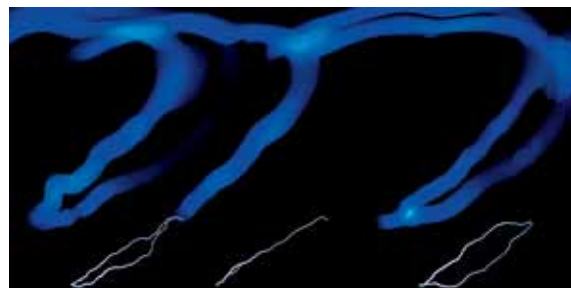

Costis
3=1



Judith Cottrell
Untitled



Lisa Rybovich Crallé
Tuxedo Park: Glove



Holly Crawford
Letter to Sol



J.J. Cromer
My Mealtime Prayer



Ken Cushman
no title



Soren Dahlgaard
Karoline, 15



Dana Dal Bo
Creature #32

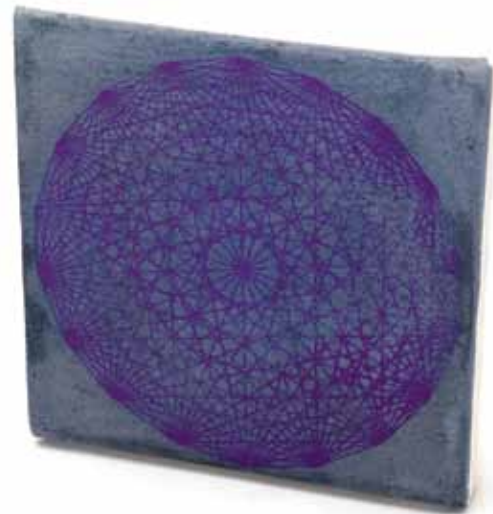

Mark Dagley
no title



Lisa Dahl
no title

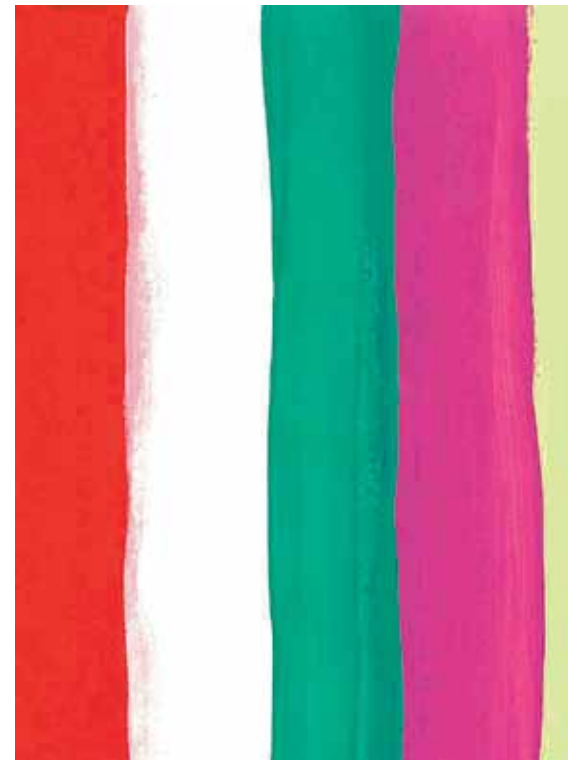

Kasarian Dane
Untitled

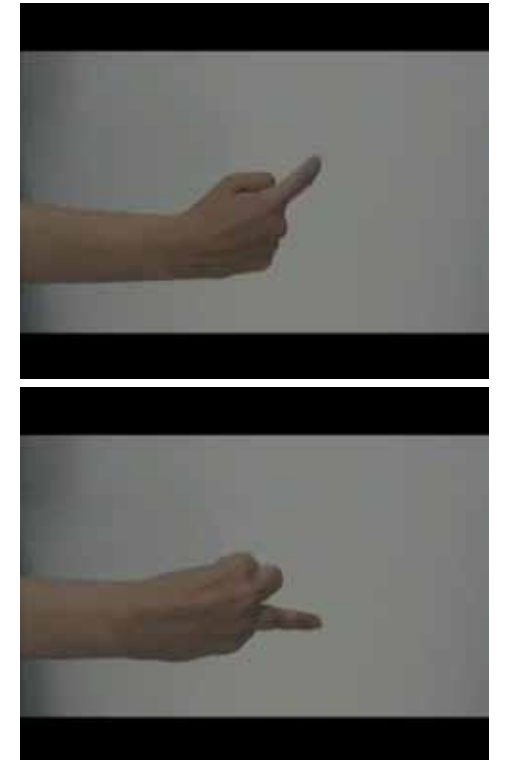

Dina Danish
Counting



Julie Davidow
Diagram #3



Kate Davis
"You seem the same as always, -"

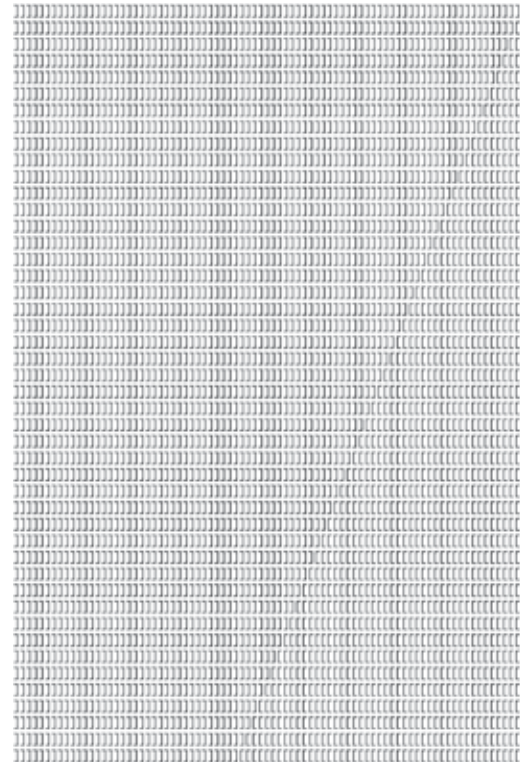

Caroline De Lannoy
Shaping Space



Eric de Leon Zamuco
Beginning Drawing No. 1



Julien de Bock
Siberian Cemetery, Kuanda



Tara de la Garza
Sol distortion 1

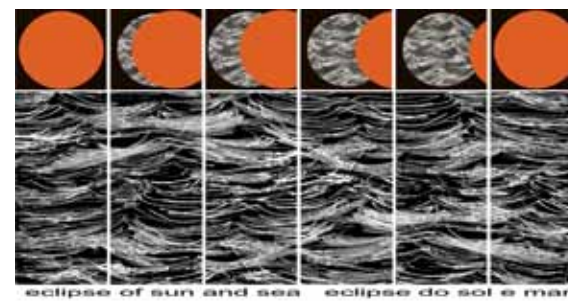

Lenir de Miranda www.lenirde.com.br - Fotos: RB, B&B - Editora de Sol e Mar - 2010

Lenir de Miranda
Eclipse SOL e Mar



Jason Dean & Matthew Nash
Every Permutation of Four Guitar Chords Performed Live & Uninterrupted: Would Sol LeWitt Approve?

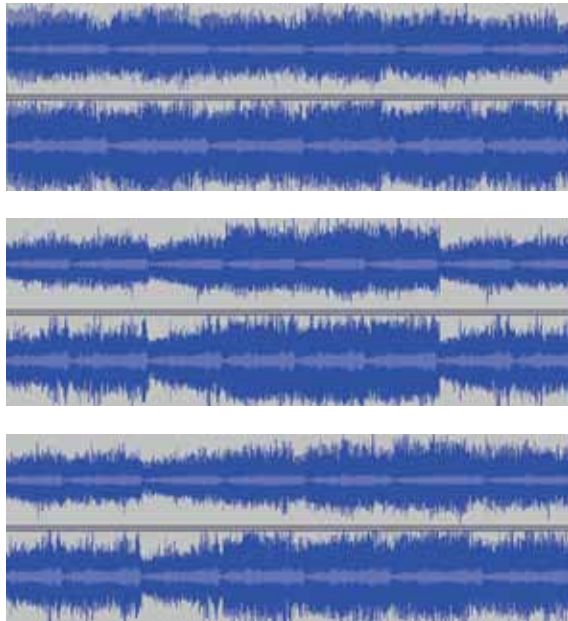

Alessio Delli Castelli
Aufrichtige Anleitung

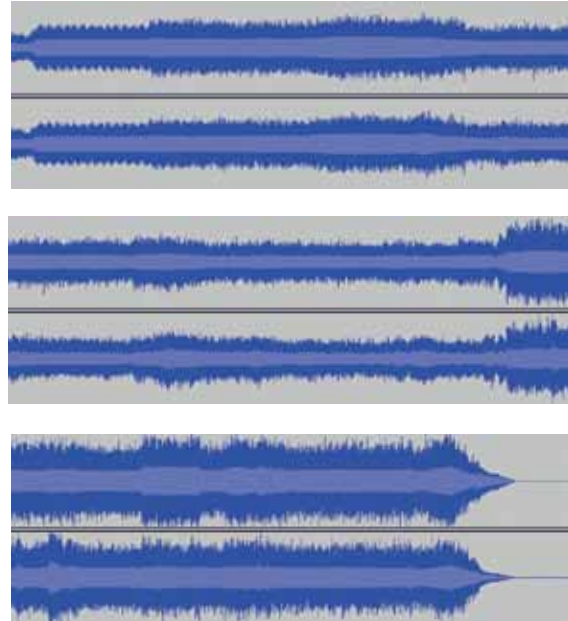

Paul Devens
Cap

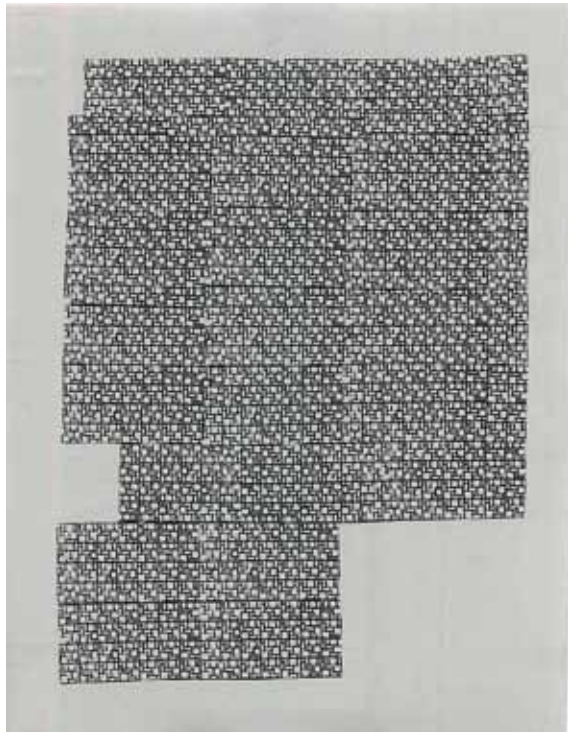

Angela Dittmar
Floor Rubbing



Milos Djordjevic
Dislocation



Edward Dorrian & Mark R Taylor
Five Years: Failure



Mario d'Souza
Converstaion

List of Curating Praxis, Techniques & the General Thoughts That Go Thru a Curators Brain When Preparing, Producing, & Curating the Spatiality of a Prominent Museum Based Exhibition

Glass Case	Black & White	Attachments
Wall Art	Venue	Pavilion
Relational Aesthetics	Permanent Collection	Ceilings
Registration	Collectors	Buses
Situational Aesthetics	Critics	Registration
Off Center	Curators	Survey
Emergency Breakdowns	Gallery Owners	Questionnaire?
Lighting	Museums	Parade
Back Lighting	Museological Placement	Movable Wall
Environments	Contracts	Trade Show
Habitat	PR	Laboratory
Traveling	Advertising	Guards
Temporary	Barriers	Demonstration
Color	Staircases	Dust Proofing
Planning	Pedestals	Flow
Production	Arrangements	Observation Sites
Dancers	Compositions	Plants
Presentation	Timing	Projections
Books	Security	Rotations
Specificity	Protection	Sound Systems
Book Store	Methods	Cash Bar
Scale	Contemporary	Invitations
Publications	Insurance	Map
Ephemera	Crafting	Community
Didactic Information	Font	Decoration
Side Show	Approach	Mechanics
Social Media	Labels	Temperature
Performance	Paok	Touching
Documentation	Photo Murals	Grid System
Devices	Minimal	Art
Audience	Representation	Flux
Viewer	White Cube	Interior
Duration	Video Room	Exterior
Framework	Seating	Nuclei
Labeling	Distribution	Censorship
Transportation	Recombination	Consultants
Traffic Flow	Size	Private Viewing
Oculus	Weight	Women Eye View
Schedule	Volume	Birds Eye View
Education	Information Booth	Laws
Structural Frame Work	Host	Local Juxtapositions
Acknowledgements	Attention	Global Implications
Bibliography	Set Up	Cutting Edge
Index	Display	Envelope Pushing
Codes	Tools	Empowerment

Pete Driessen © 2018 Series of 100 Signed Limited Edition Copies on Lime Green Paper Original Signed in Black Sharpie Marker

Pete Driessen
List of Curating Techniques



Spartak Dulic
Idea-Launcher



Chris Dupuis
no title



Boris Dworschak
Fujikawaguchiko



Bryan Eccleshall
Sentences on Conceptual Art Colored in Red, Orange, Yellow, Green, Blue, Purple



Stephan Ehrenhofer
k27_xl_43_sol



Mary Early
Untitled



Jeff Eaton & Pablo Helguera
A Perpetual Gift of a Collection of Alain Robbe-Grillet Texts to a Young Artist, via Sol LeWitt



Brandy Eiger
Sweltering Sky



Elizabeth Enders
Untitled/Volcano



Rob Engvall
After Sol LeWitt, Wall Drawing 915 + 396

Personal:

Name: Diana Combo (a.k.a. Eosin)
 Website: www.eosinnoise.wordpress.com
 Email: combo.diana@gmail.com
 Phone: +49 (0)15778967702 / +351 926035335

• Title: **Linnut** (sound piece)

Linnut is the first of an ongoing series of compositions I'm making using vinyl lock grooves and field recordings. Somebody asked me: What is this track about? What is it's story? I don't know about it's meaning and it's story lies on the procedure of it's own production.

For my participation in Tinynoise festival, last October, I got two Staalplaat Soundsystem LP made for Yokomono that I was experimenting real time during my performance, this is, I was listening for the first time and using the lock grooves combining them with pre-recorded sounds I had already edited. I enjoyed the result and the loops inspired me to use them as a structure for further tracks. I recorded some mixes and then edited, creating a sequence to which I added a parallel layer made of field recordings of various sources. It's analog and digital, improvisation and control, processed real time experiments.

Sounds: Yokomono 02 and 03 lock grooves (Staalplaat) + Field recordings

Duration: 00:10:58

More info about the records used:

Yokomono 02
<http://www.staalplaat.com/search/catalog/14269>
<http://www.discogs.com/Various-Yokomono-02-55-Lock-Grooves/release/506491>

Yokomono 03
<http://www.staalplaat.com/search/catalog/14851>
<http://www.discogs.com/Various-Yokomono-03-55-Lock-Grooves/release/583052>

(Download link: <http://www.mediafire.com/?7yev9byz2umad> or <http://www.poemproducer.com/2/linnut.mp3>)

Eosin (Diana Combo)
Linnut

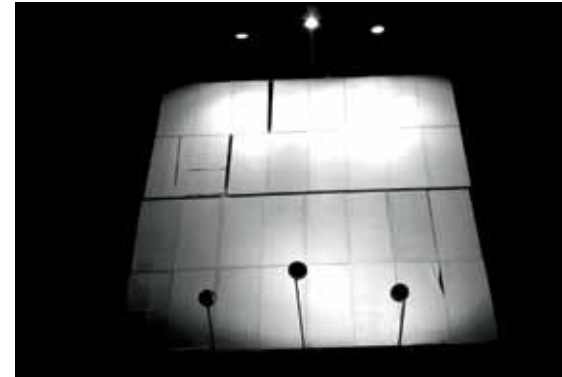

Verónica Rojas Espinosa
ABSENCE



Jan Estep
On Certainty

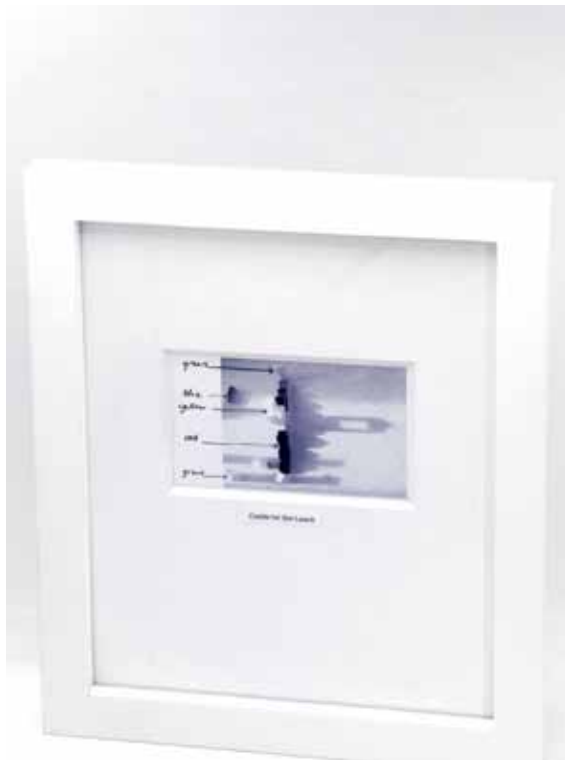

Catherine Haley Epstein
Castle for Sol LeWitt



Cevdet Erek
Ruler 0-Now



Mary & Matt Even
Chocolate Editions



Arturo Evening
17 for Sol LeWitt

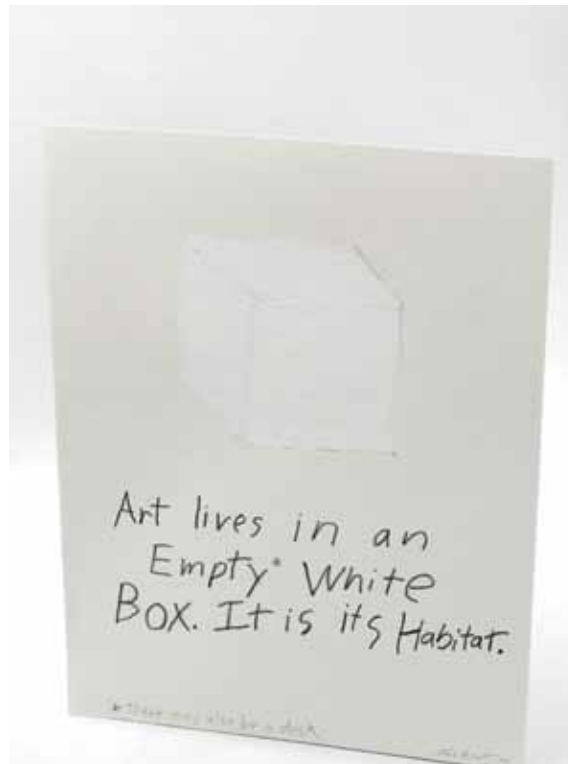

Lee Everett
no title



Bruce Eves
1969 (Updated): After Sol LeWitt



Annie Farrar
Test Pieces



Siobhan Feehan
Squirrels

An Exchange with Sol LeWitt

While looking at the Sol LeWitt: A Wall Drawing Retrospective exhibition at MASS MoCA this summer, I was particularly drawn to the pieces like Wall Drawing 473, or Wall Drawing 1211, that emphasized the variation possible within a tight constraint of four patterns of lines or four colors. I kept wondering how these drawings would sound when played by someone on a guitar, or better yet, several people playing them on guitars. As minimalistic works of music, this performance would be a wonderful voicing of Sol LeWitt's concepts.



For this exhibition, I propose creating and producing a new work of music to be performed live and then offered as a recorded piece in conjunction with the wall drawing retrospective.

Working directly from Mr. LeWitt's instructions, like the diagrams painted on the walls at MASS MoCA, in collaboration with local recommended guitarists, we would rehearse and perform the aural equivalent of pieces that focus on variations of numbers 1, 2, 3 and 4 in the sequences mapped out by LeWitt.

Ellen Hackl Fagan
no title



Jonathan Farber
Iron Peanut

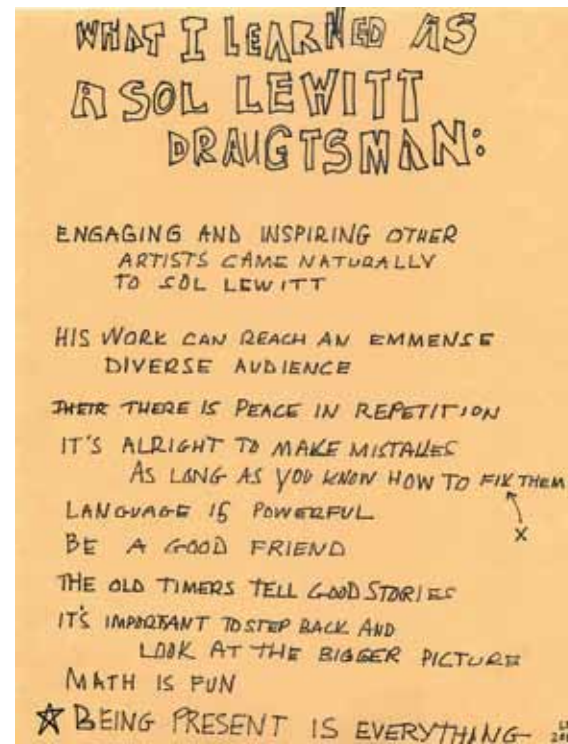

Lacey Fekishazy
Learned LeWitter



Doris Fend
2-green

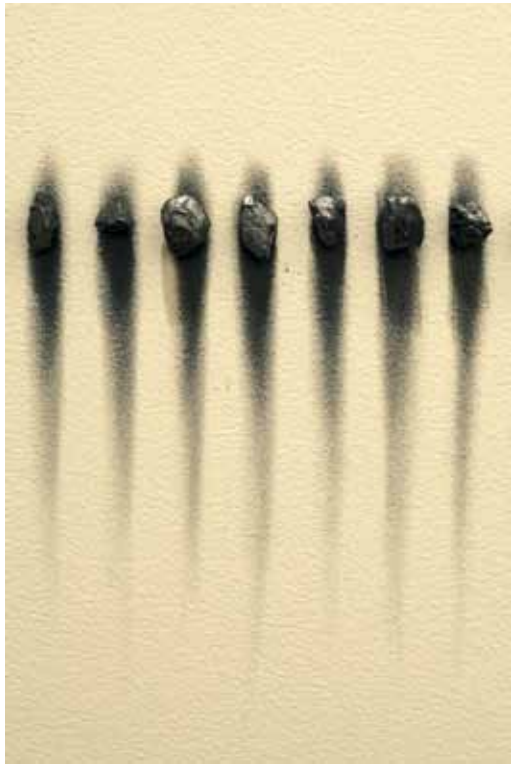

Teresita Fernandez
Untitled (LeWitt Exchange)



Wouter Feyaerts
no title



Liliana Fijman
A Matter of Symbols



Paul Fiore
Pallet Knife Expression



Susan Field
Book 7.16



Kim Fielding, Tom Goddard & Tiff Oben
Chav at First Sight



Kerstin Fischer
little silver trophy



Martina Fischer
no title

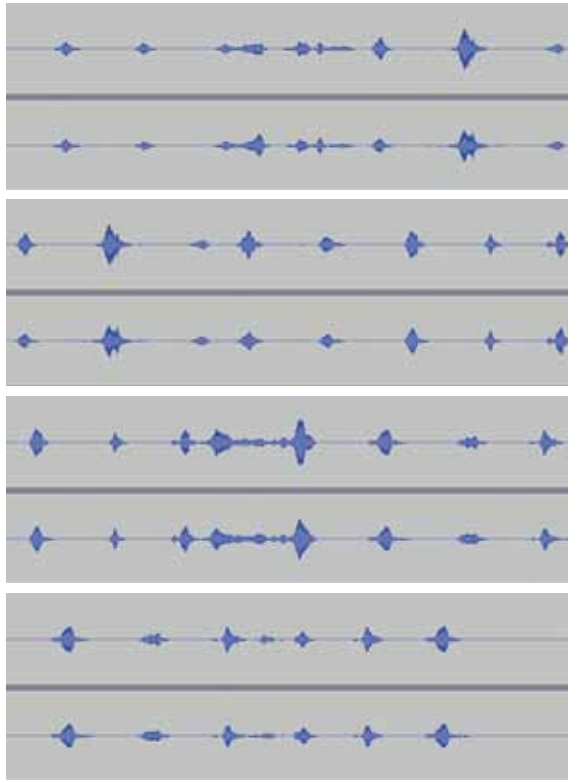

Andrea Flamini
Room 405, Pace 1, 5 Measures



Harrell Fletcher
Corentine 4



Andrea Frank
Impermanence



Lorrie Fredette
Some family and friends telling me what to draw so I can exchange with Sol

SYMBOLIC STORY
 I I I I I
 o, >o, *o*, ^, ^,
 a :O. :O. :O.
 Oς . ς . ς . ς

DAF 20

Deirdre Fox
Symbolic



Stephanie Francis
Sand from Tottori, Japan



Veronica Frenning
Pacer Is Losing Feathers

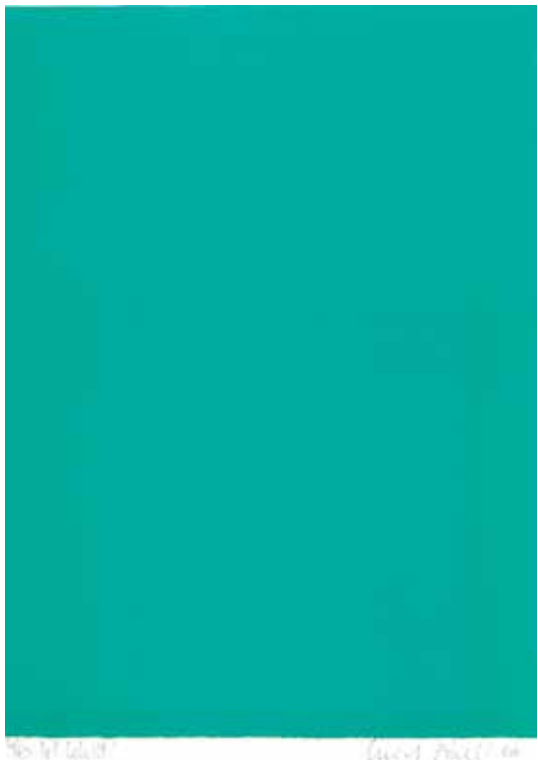

Heribert Friedl
For Sol LeWitt

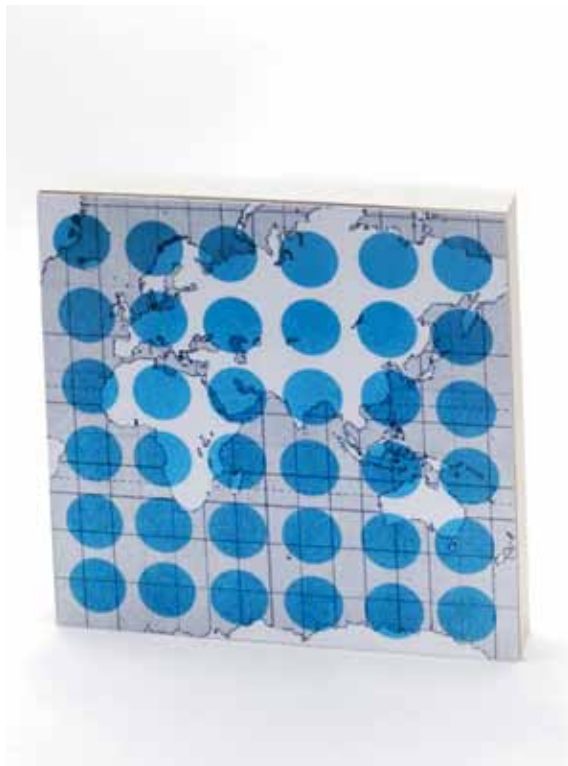

Manuela Friedmann
Blue Grid #51



Sven Froekjaer-Jensen
A tribute to a searching soul - In and beyond constructivism lives the mystery.

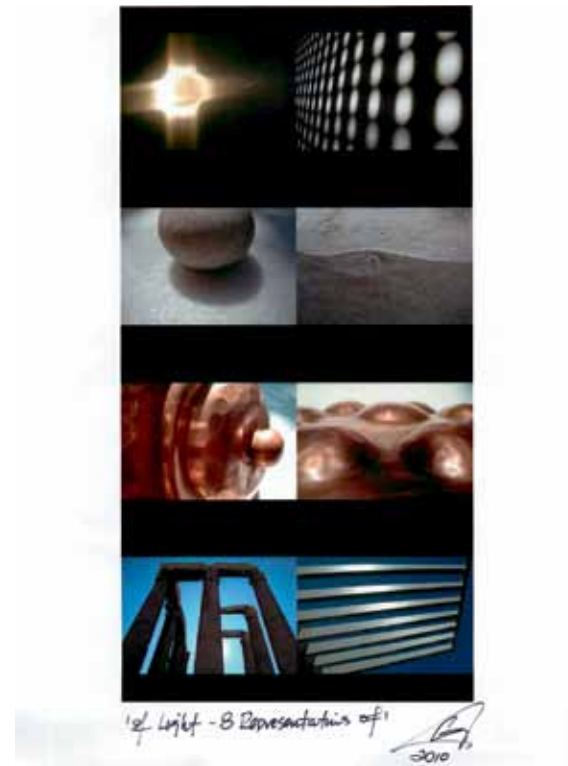

G
of Light—8 Representations of

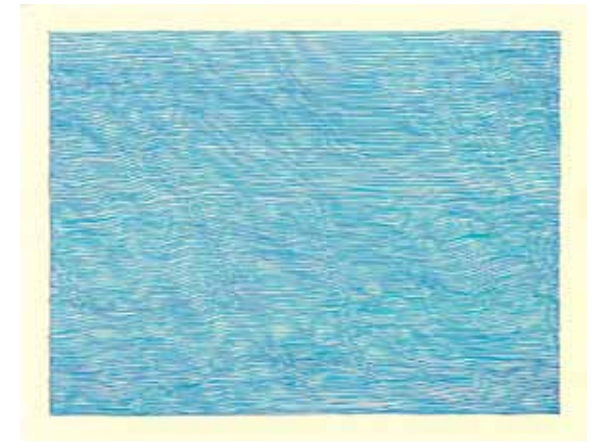

Heidrun Gabel-Koeppf
The Beauty of Lines



Gerhard Frommel
Yet to Be Found



Leslie Fry
Small Arms



Veronica Gabrielse
no title



Ted Gahl
Clone

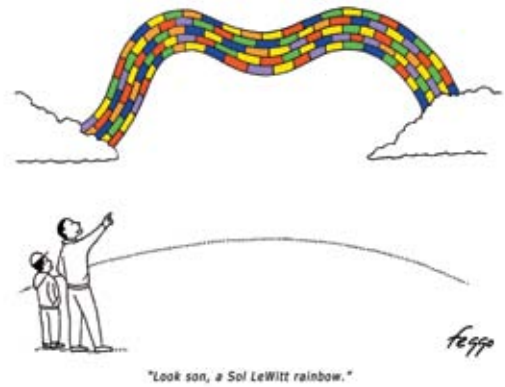

Felipe "Feggo" Galindo
Sol LeWitt Rainbow



Jenny Galipo
Gargling Milk and Cutting Bushes



Max Garrett
Strong and Absorbent Family Napkins

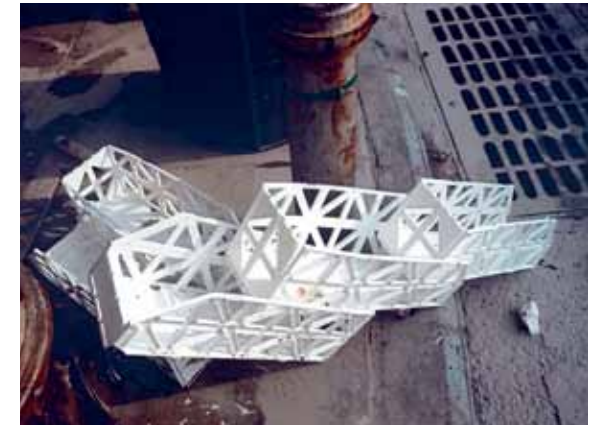

Joy Garnett
Found Art #43



Paul Gallo
 no title



Pam Garber & Xenia Pachikov (Empty Purse)
Napkins



Sid Garrison
 no title



Maria Garton
Liverpool Street Salford



Till Gathmann
Proposal for a Wall Drawing



Claire Gavronsky
Real Line (ink drawing)



Jeffrey Gibson
Untitled



Nuno Gil
Untitled



Moira Geoffrion
Corazon Grids



Laura F. Gibellini
In Habitation I



James Gilbert
You Think We Know Too Much?



Jenne Giles
Untitled (Felt Painting)



Hope Ginsburg
Pencil Sharpener



Helidon Gjergji
Piggy Banks



Matthew Goddard-Jones
Pastimes // Early Morning Swim / Perth, Western Australia



Corin Godfrey
The Winter of Our Digital Content

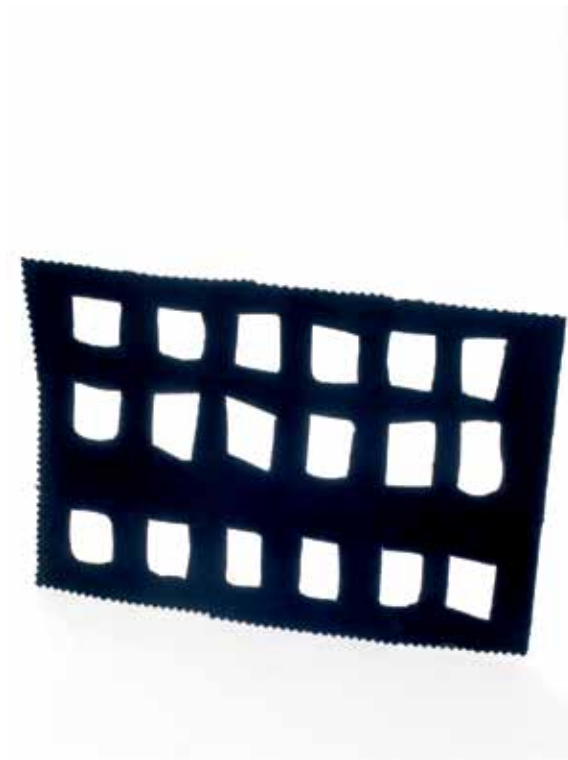

Cora Jane Glasser
no title



Jessica Alice Gnyp
Untitled (Floating)

Imagine a line (30 inches long) on this piece of paper.

Monika Goetz
Imagine a Line



Max Goldfarb & Allyson Strafella
[Artifact of Sol LeWitt's] Irregular Arcs, Vertical Bands, and Irregular Wavy Bands



Charles Goldman
2x4x8x (edition)



Ricardo Leal Gomes
Untitled (Cabinet of Curiosities)

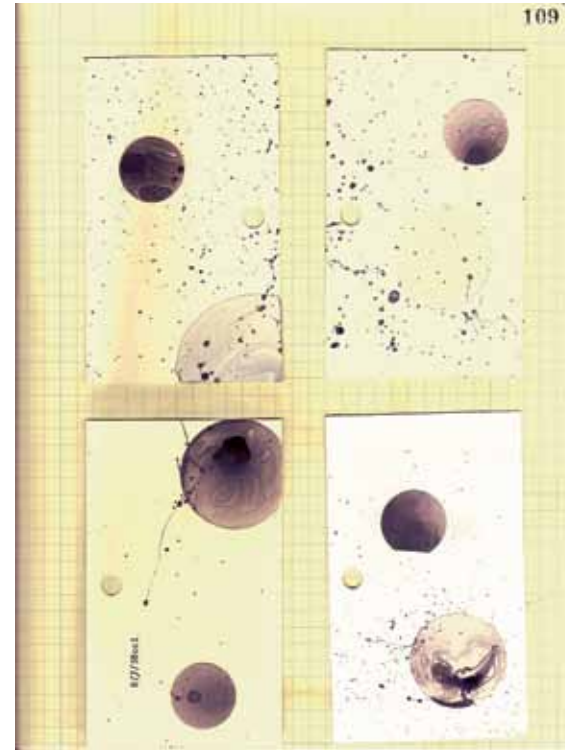

Kathy Goodell
no title



Jenna B. Gotthelf
no title



Cassia Goncalves
1 & 2 from Serie: Corporality: Forms and Matter from Nature



Jesse Good
Sniffin Griffin: For Sol



Elizabeth Gourlay
Dots + Stripes 4

Terence Gower
Dessicated and Reconstituted
To be stenciled high on the wall, 8 feet long.

DESSICATED AND RECONSTITUTED

Terence Gower
Dessicated



David Grainger
Q-Bert



Ann E. Grasso
SEED MONEY

1 - I took a photograph of a sky.
2 - I sent the negative to a lab.
3 - I asked them to print a beautiful sky.
4 - Repeat 2-3.



Julio Grinblatt
Cielito Lindo



Ariel M. Gruell
no title



Anna Lena Grau
Kippwurfel #1 & Open Gravity Structure



Chris Griffin
Remembering Sol in Italy

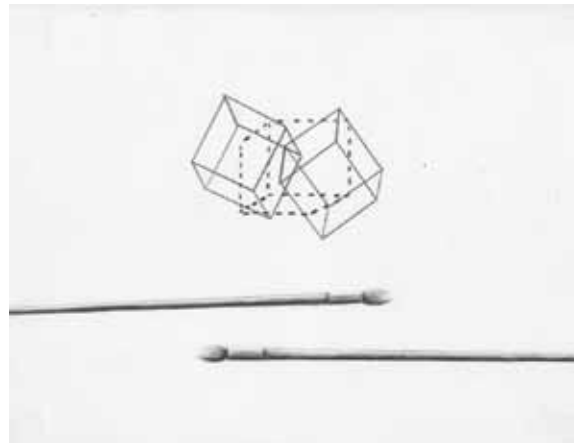

Ufuk Gueray
Floating Cubes



Colin Guillemet
Fake Tan Lines / Sol LeWitt



Karen Gunderson
Water for Sol



Zannie Gunn
Ways



Adam Hall
Twins



Heidi Hankaniemi
Domesticising Sol LeWitt

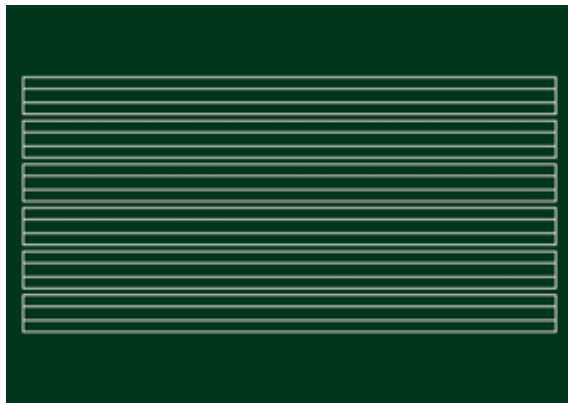

Anette Haas
Lineatur

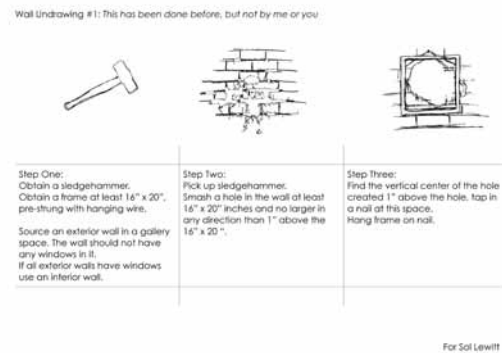

Belinda Haikes
Undrawing #1



Lucia Harrison
no title



Matthew Harrison
A Gift



Susan Rowe Harrison
A Natural Study in Lots of Lines



Kelsey Hawk
11 Knots



Deborah Hede
Double Transport



Walter Hekster
Music for Sol LeWitt



Daniel Healey
no title



Sarah Hearn
Box of Evidence

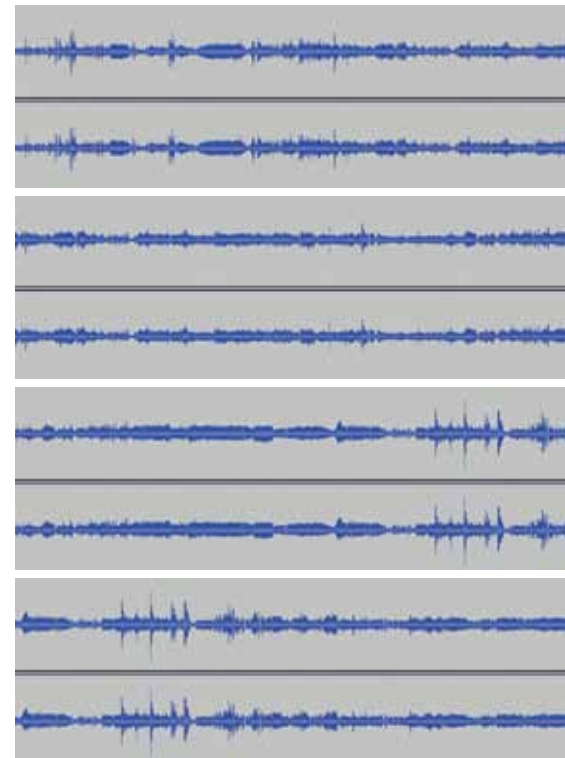

Lynne Heller
Gift



Karen Hennessee
Shadow

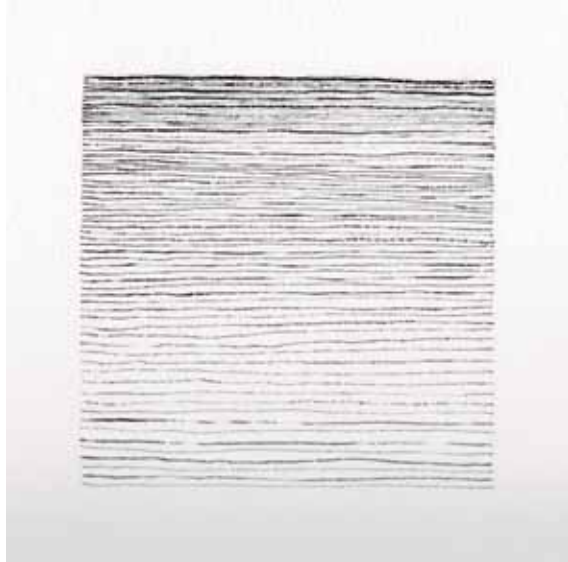

Molly Heron
Lines 21.02



Elana Herzog
no title



Andrea Hinds
Mornin' Katherine



Valerie Hird
no title



Raul Hidalgo
Unemployed Display—Sculptures On



Sarah Hildebrand
Mon jardin



Brian Hitzelberger
Untitled (Window)



Christopher K. Ho
Jackson Hole Time Machine



Laura Holland
Glossy Black Surface; Large X; Concentric Rings and Rafters

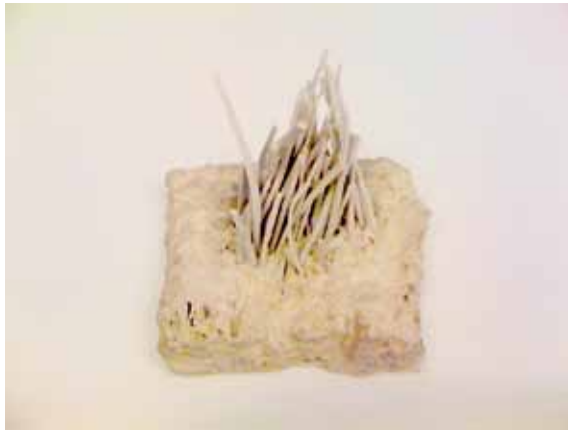

Eric Hollender
What Sol LeWitt Might Like



Lindsey Hook
What I Wanted

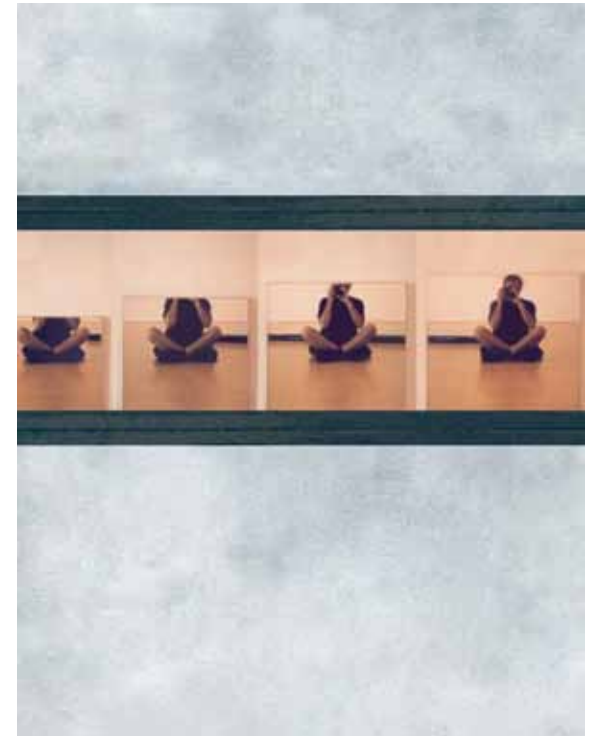

horea
Self-portrait in Sol with Don, Dan, Bob



Karl Holmquist
 no title



Honorita
Mail Art 4 Sol LeWitt



Grier Horner
Bust of Sol with Glasses

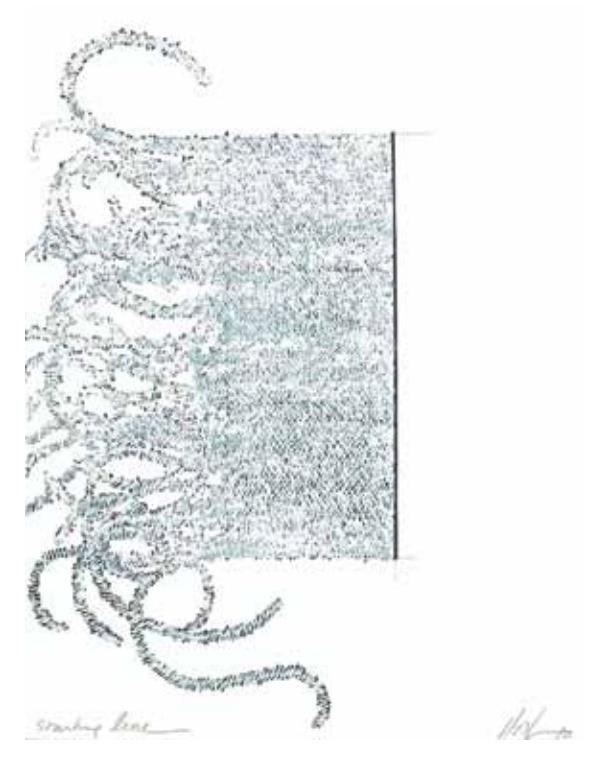

Lyn Horton
 no title

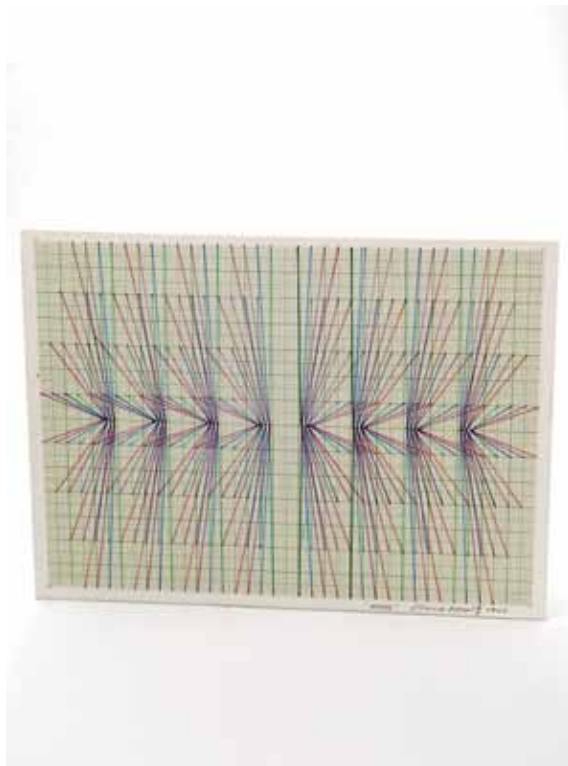

Channa Horwitz
For: Sol's Family



Joelle Hotaling
no title



Amila Hrustic
no title

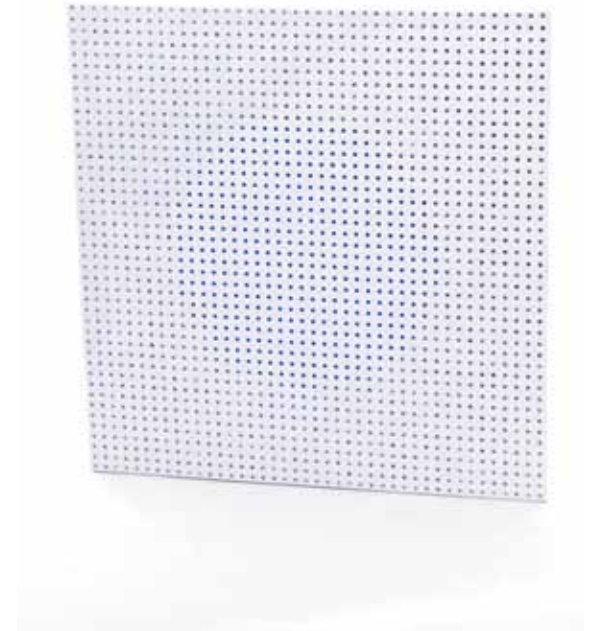

Gilbert Hsiao
Blau Kreis

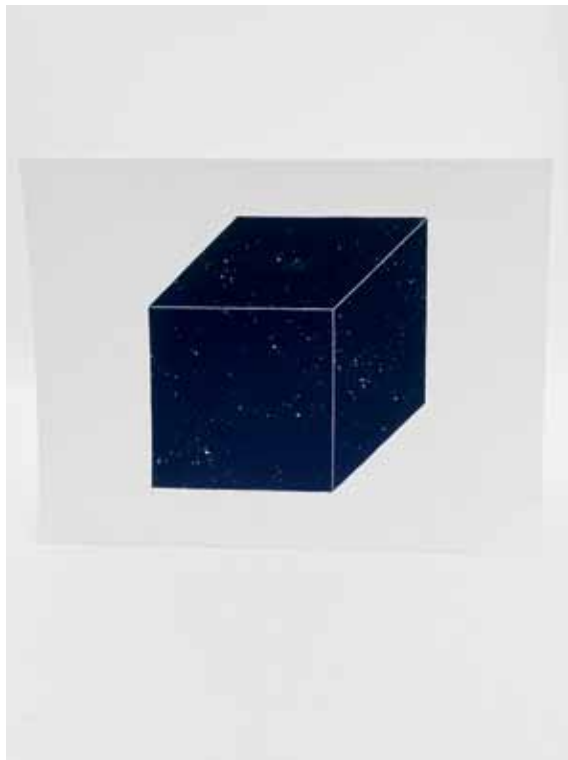

Sarah Hotchkiss
Drawing for Sol LeWitt (Night Cube)



Iris Hrasovec
Touch of Light



Barry W. Hughes
Werner's Geburtstag



Holly Hughes
Deruta Conversation



Nene Humphrey
From Me to You: Speech for Sol



Cheryl Huntbach
no title



Raymie Iadevaia
New Art Kit



Richard Ibgby & Marilou Lemmens
Untitled (Triangular Prisms)



Yarim Hur
After Sol LeWitt, Wall Drawing 610



Taisha Hutchison
Keynote



Ida
no title



Mana Ikeda
Lines That Connect: Wall 51 + 130



Irene Imfeld
Rhyolite Bank (0854)



David Ingenthron
no title

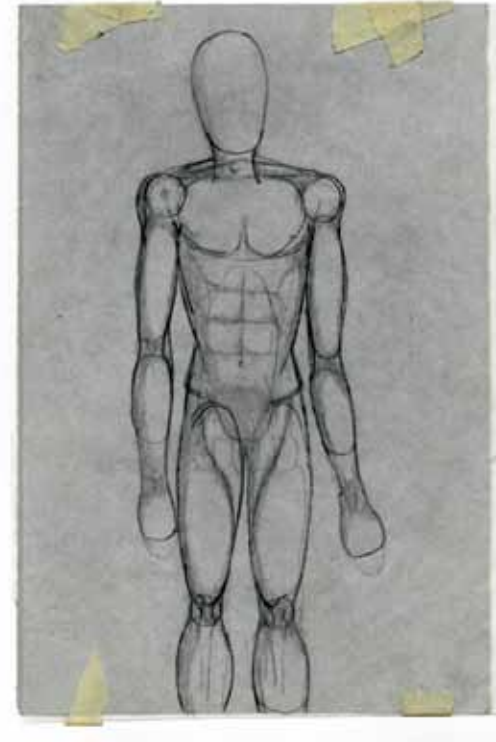

Damian Jordanov
Renaissance Man



Philip Losca
Untitled (Box with Gold Inside)

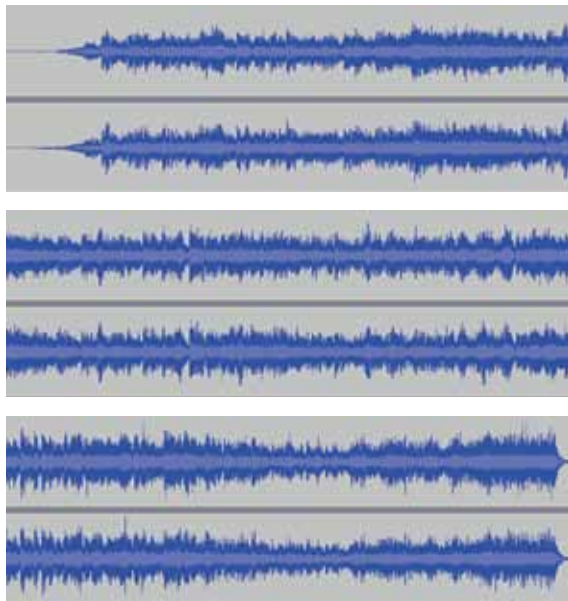

Jeremy Inglis (MODrn)
1(4,5)7001



Kelly Falzone Inouye
no title



Matt Jahmer
Blueprint for Destruction



Jörg Jakoby
Untitled (RGBYKW-102)



Karyn Janowski
Los Angeles Red Line subway map and token (for Sol)



Thomas Jarvis
Whose Line Is It



Da Young Jeong
After Sol LeWitt, Wall Drawing 439



Daniel Joglar
an image (for Sol)



Matthew Jensen
14 Hour Sunset, over the Alaskan Range



Hye Ram Jeon
no title

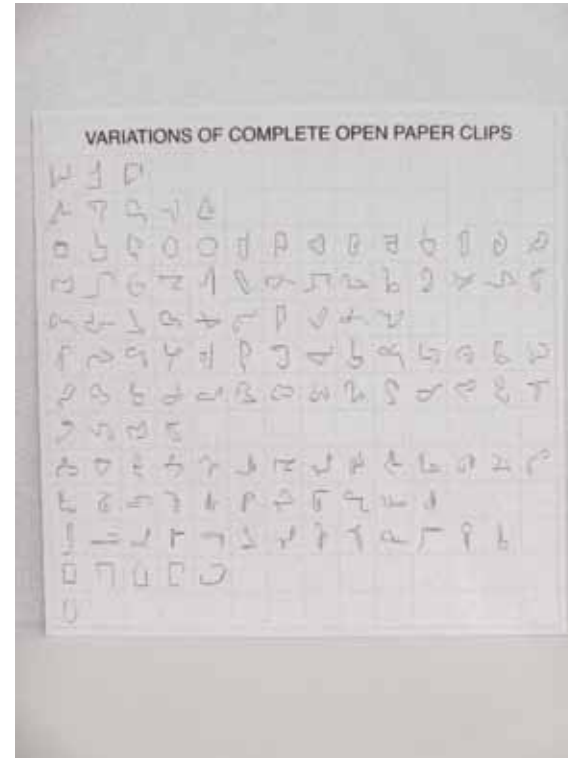

Joe Johnson
Variations of Complete Open Paper Clips



Kate Johnson
Less Than or Equal To

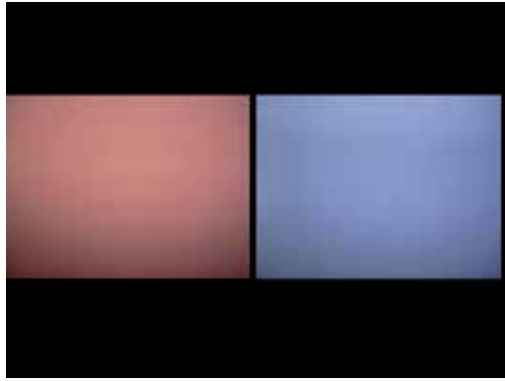

Luke Johnson
Waiting for Sunrise

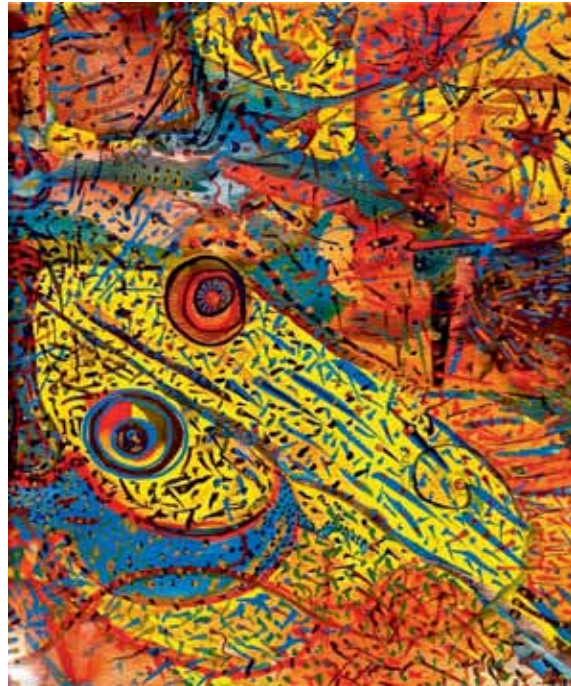
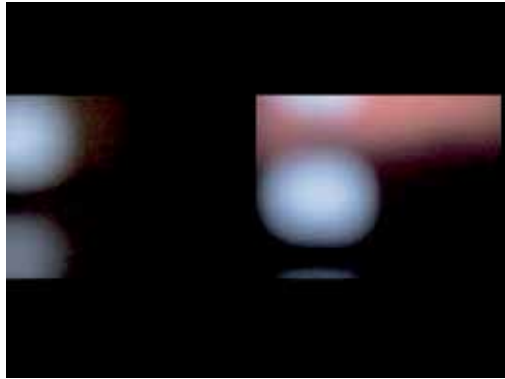

Mary Johnson
Fish and Cookies



Pierre Juillerat
C_51.310

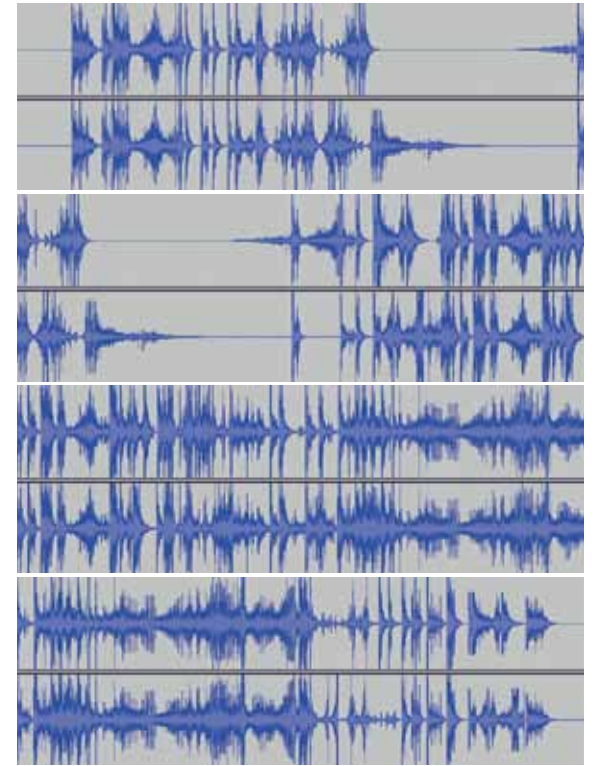

Timo Kahlen
White China



Jeffrey Cortland Jones
Touching from a Distance

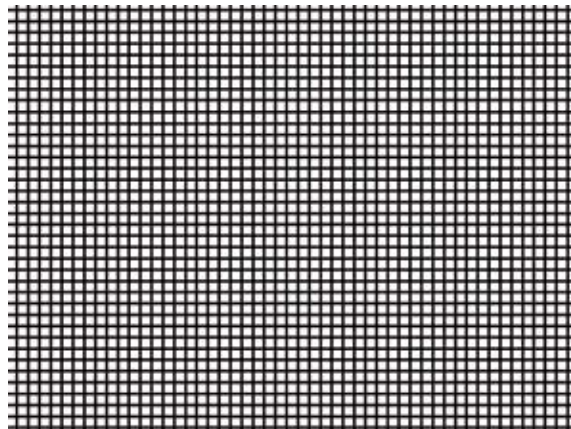

Klaus Jörres
NOW

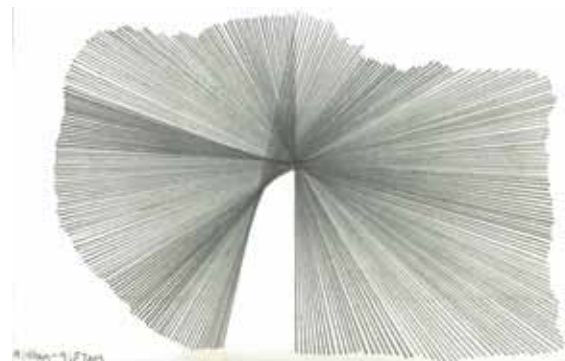

Robin Kandel
9:40 AM-9:57 AM

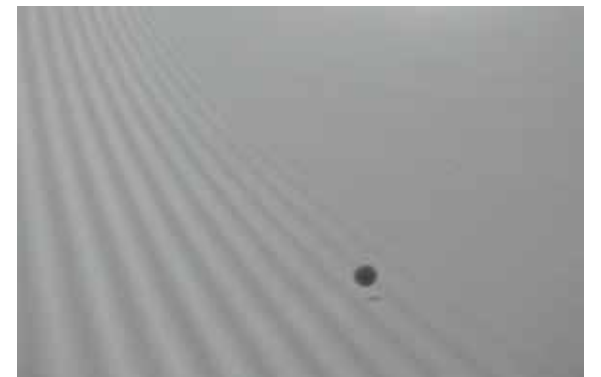

Sun Mee Kang
Weightlessness-L200910

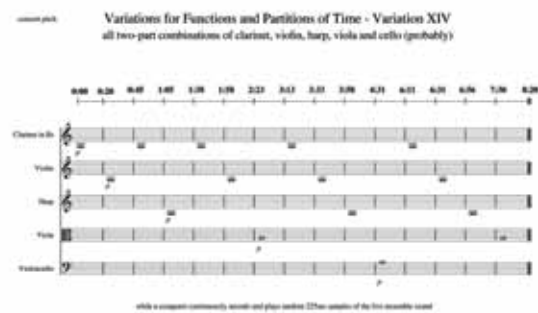

David Kant
Variation XIV (for Sol LeWitt)

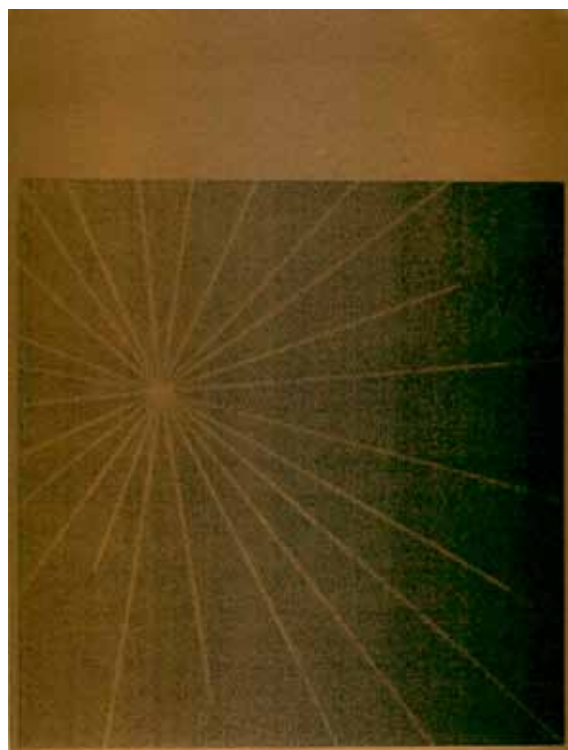

Gregory Kaplowitz
Untitled



Kazuko
My Foot Looking for Water

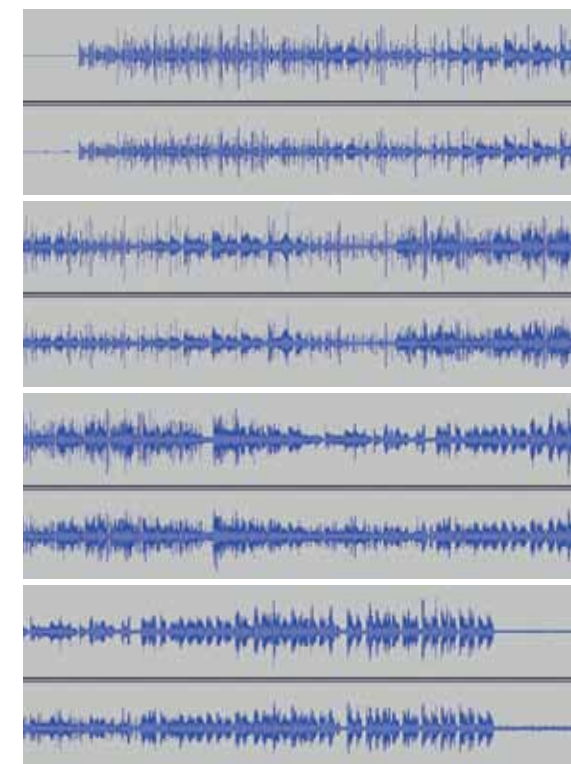

Zachary Keeting
Morro Castle



Marina Kassianidou
Untitled



Marie Kazalia
Line



Mary Kenealy
Revolver Series



Sam Keogh
no title

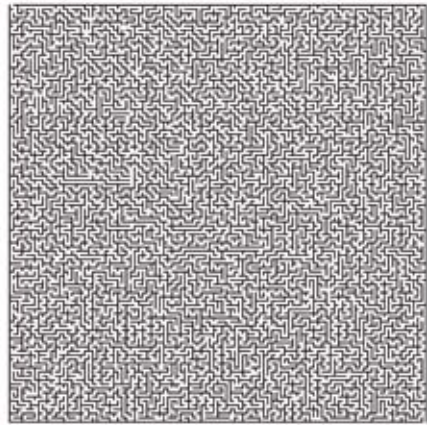

Iordanis Kerenidis & Piergiorgio Pepe
an impossible maze (for Sol)



Nicholas Kersulis
Everyday Objects for a Table



Angela Kim
Untitled



Cheonae Kim
Mediterranean



Dean Kessman
no title



Khalid Khan
no title



Hyo Myoung Kim
Nineteen Eighty-Four (enciphered in colour)



Julia Kim
After Sol LeWitt, Circles



Maritza Ruiz Kim
From Sol to Eva

AN OPEN LETTER TO SOL LEWITT & FRIENDS, 10/2010

Dear Mr. Sol LeWitt, I write to you today concerning Lars von Trier's new film *Antichrist*. Have you seen it? If you haven't I won't bore you by recounting the plot. Though you should know that both the official trailer for *Antichrist* – and some of Lars von Trier's own descriptions for the film are inadequate and misleading. I suppose that one could nominally describe the film as being "a psychological thriller that evolves into a horror film." And according to the official blurb: "A grieving couple retreat to 'Eden', their isolated cabin in the woods, where they hope to repair their broken hearts and troubled marriage, but nature takes its course and things go from bad to worse[.]". But of these unhelpful, rather conventional readings somehow miss the point. The miracle of *Antichrist* is not so much the explicit narrative that more or less holds the incongruent elements together. But it is precisely the latent excess within what is so often misread as "nature" – a homeostatic, balanced, near pagan, New Age Gods mother earth – that is so miraculous. I don't want to get too carried away here with my analysis, but for myself *Antichrist* perfectly sheds light on certain of Heidegger's course lectures from 1929 & 1930 concerning the infinitely nihilistic dimension of nature. Here is the Hegelian philosopher Bink set again on the task: "Heidegger, towards the end of the chapter concerned with these notions, proposes – in a Schellingian mood – a daring speculative hypothesis that perhaps animals are, in a certain unknown way, aware of their fact, of the 'journey' of their relating to the world – perhaps there is an indelible pain pervading the whole of living nature. If devastation in certain forms is a kind of suffering, and poverty and deprivation of world belongs to the animal's being, then a kind of pain and suffering would have to permeate the whole animal realm and the realm of life in general." I said "in a Schellingian mood" because Schelling wrote about the "infinite melancholy" of all living nature, about how there is an infinite pain and craving in nature, since nature is caught in an unresolved absolute tension, torn from within, unable to "reach" or define itself – which is why the emergence of logos, of the spoken word, in man is not simply an excess that disrupts the balanced natural circuit but an answer to this infinite pain and deadlock of being nature, a resolution of its unbearable tension: if it is living nature itself was secretly pointing towards, waiting and longing for, the emergence of logos as its redemption." Lars von Trier, in a stunningly modern move, takes and runs with the Heideggerian/Heideggerian/Schellingian mood and dares to add his own speculative nihilism/realism that perhaps logos and language (and even synchronicity itself) aren't answers to anything, certainly not answers to the infinite pain and deadlock of being nature. It is not why even with all of his clever framing and patient probing queries, Willem Dafoe is utterly impotent in actually helping Charlotte Gainsbourg? What if the spoken word is simply another mutation of this unbearable tension? I watched *Antichrist* with my friend, the video-performance artist Gina Clark – and at the very moment in the film that the idiosyncratically well fox mouthed the word: "Chaos reigns," to Willem Dafoe, she neatly shut in her pants and ran out of the room genuinely terrified and unreserved. It is not proof positive that spoken words far from redeeming us, disrupt us left – alienates us from what was originally alien and therefore unknown? It is precisely here (while we are virtually at the end of the previously open letter, a three-hour, masturbatory thinking-out-loud session that I want to apologize for I have set to really get to the sensitive and really question, if you weren't aware of it already, the point of this writing exercise was to provoke you that way). Are you aware that *Antichrist* additionally proposes a quiet challenge not only to women & feminism – but even to you Sol LeWitt specifically? *Antichrist* isn't simply about the status of nature, but the status of cinema in relation to you and your friends. According to *Antichrist* – yes, it may be the case that patriarchal logos is indeed impotent, and really isn't the redeeming feature, but guess what? Cinema is. Cinema can do what animals inspired art (like Sol LeWitt's ink and pencil drawing on paper *Formless Projection #11*, 1981) can't do: an effectively male-dominated cinema can not only redeem us – it can also act as the aesthetic exception to the universal rule or series (all men have inalienable rights – with the exception of madmen, criminals, primitives, the uneducated, children, etc., etc.). The corollary to this is of course that all other movies that deal with a hysterical woman who intentionally tortures her child and tortures her husband is plainly misogynistic and therefore condemned – except this one, this film is not simply an example of avant-garde cinema: it is the *Musée Grégoire* that transcends the countless series (of the misogynistic elements belonging to the universal). I urge all conceptual artists: Please watch the movie, if you haven't already, and tell me what you think. According to Julia Hall, "to say it was nobody pornographic and sexually pedantic, would be an understatement. It was visually breathtaking and emotionally painful and in von Trier fashion completely misogynistic. I was wondering how others have taken it." How do you take it? Is it misogynistic? Am I a misogynist for being the first? Is it a challenge? Yours sincerely, Maxi Kim, SDCHUB@GMAIL.COM & beoboungill.wordpress.com

Steve Zlotz, *The English Abstract*, London: Yeno 2006, 67 & 93.

Maxi Kim
An Open Letter to Sol LeWitt & Friends, 10/2010



Jamie Kirkland
Inland Waterway



Marilyn Kirsch
The Sun in SoHo



Soo Kim
no title



You Jin Kim
After Sol LeWitt, Wall Drawing 610



Marsha Klein
Hands, Brushes, Wingz

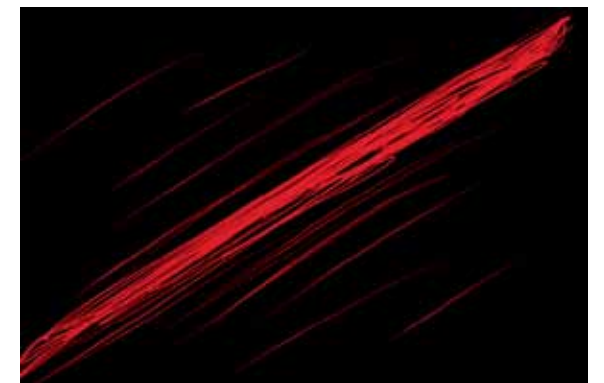

Ben Knight
Drawing for: *The Reddest Shift* for LeWitt/Yasuda/Pagk/ Farrell/etc: *Diagonal Masters*

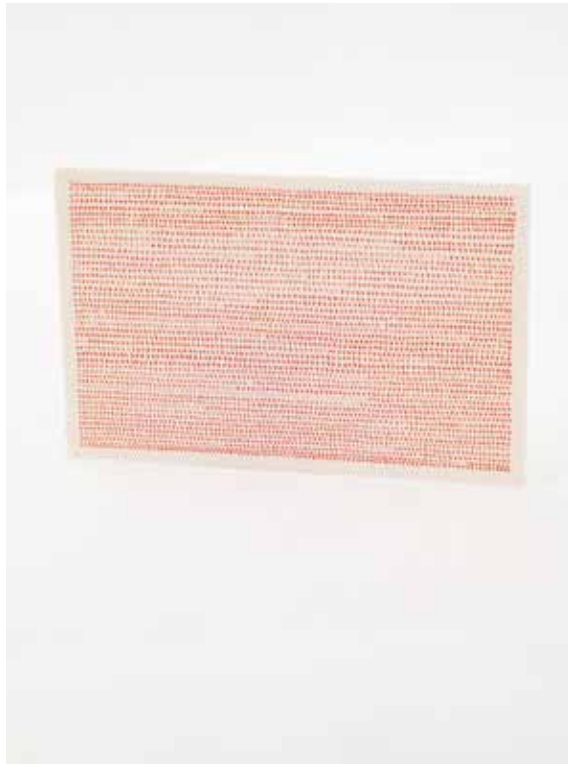

Kathrane Knight
no title



Selin Kocagoncu
Guzergah



Francine Kohn
Healing Inner Heart



Kaisu Koivisto
Cows in New York City: Reintroducing the Species

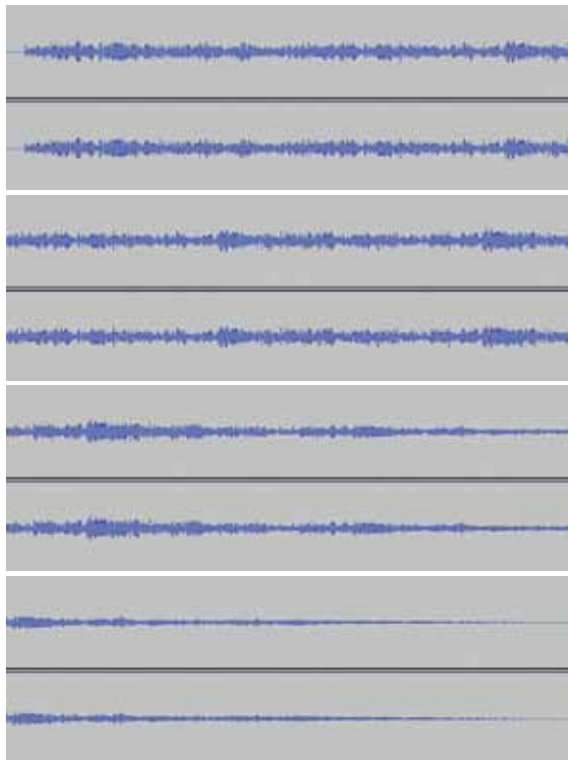

Claudia Kochsmeier
Veil



Kocot & Hatton
Make a Circle



Valerie Kolakis & Paul Landon
Blueprint for an Unbuilt House



Andreas Kopp
Liquid Air



Anna Kordsmeier
Folding Out the Table



Wynn Kramarsky
Book



Peter Kreider
Letter Head



Shane Krepakevich
Lemon Peel/Surface Area Envelope



Frank Krasicki
Waste Not Want Not



Walter Kratner
Hunger Is the Best Sauce

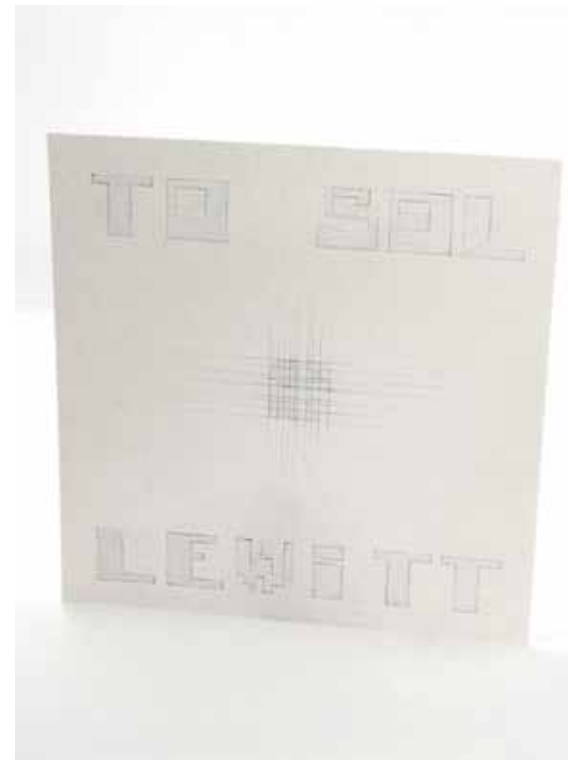

Eric Kressnig
no title

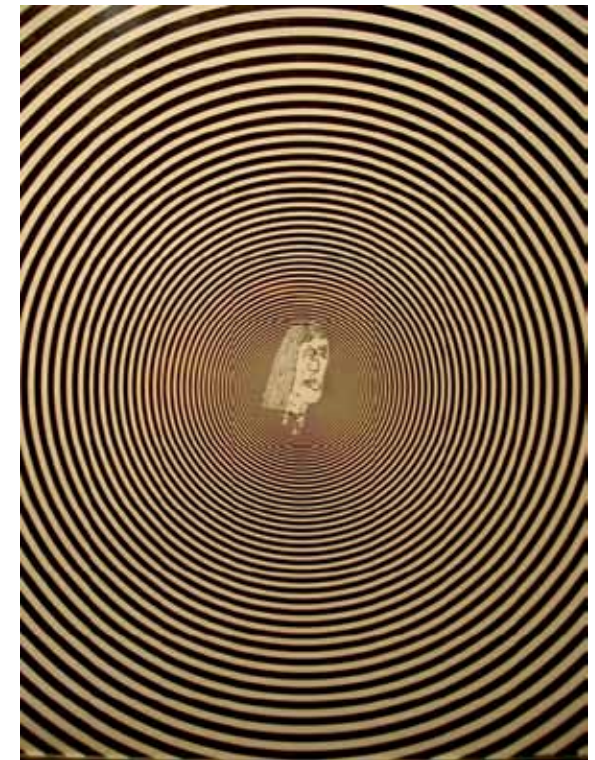

Jeffrey Kriksciun
Heady Vortex (for Sol)



Judith Kruger
no title



Adeline Kueh
Button



John Kupczak
Kaleidoscope



Michael Kuschnir
no title



Bessie Kunath
It Happened; It Did Happen



Kathryn Kuntz
Unleft



Sabine Laidig
T 8_8_8

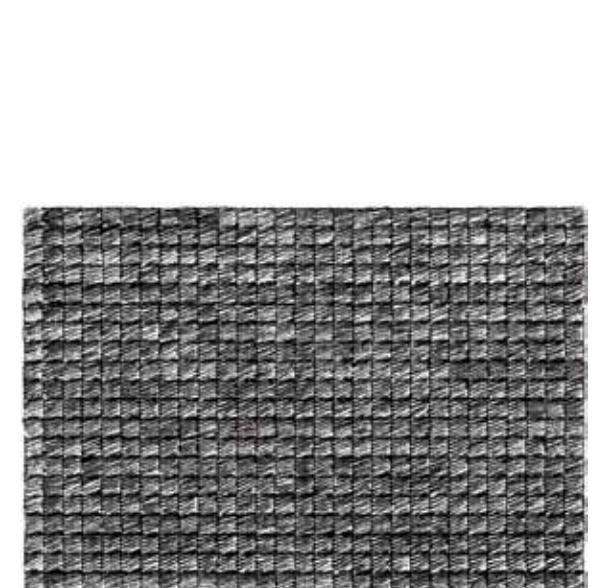

Corinne Laroche
Mes très Riches Heures - print 10/10/10

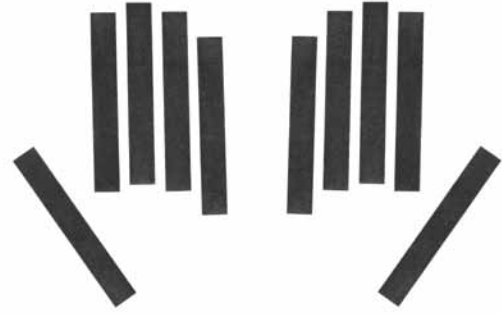

Paul Laster
A Hand for Sol LeWitt



John Latour
Two Men Holding Unknown Items



Chris Le Page
Nucleus Ship 1



Monika Lederbauer
Wintermondnacht



Louisa Lau
Red on Red



Peter Max Lawrence
Various Debris



Hui Ling Lee
Strange Food



Lee Lee
Untitled (Bottle with Liquid)

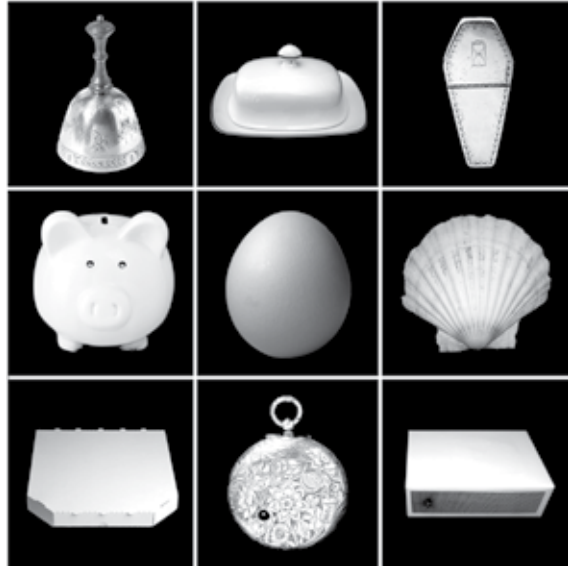

Claire Lehmann

"If the Viewer Cannot See the Interior Form He May Believe It Is There or Not but He Knows Which Form He Believes Is There or Not There"



Rena Leinberger

File No. 10273151

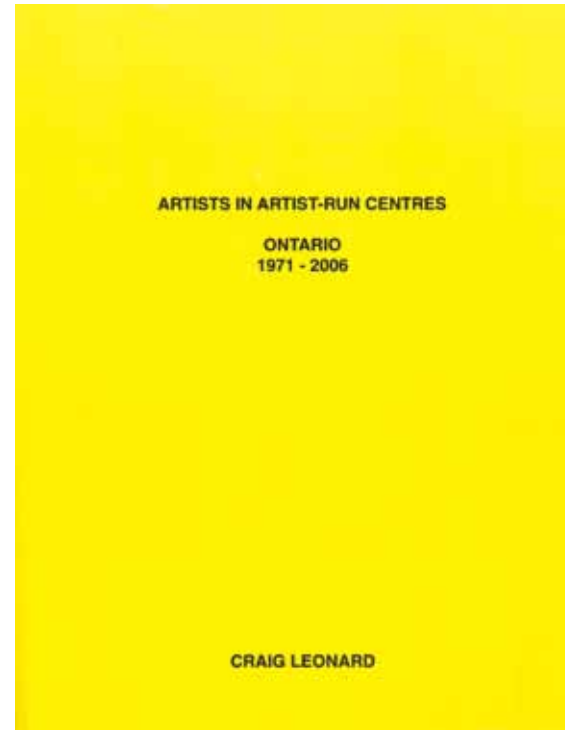

Craig Leonard

Artists in Art-Run Centres, Ontario, 1971-2006

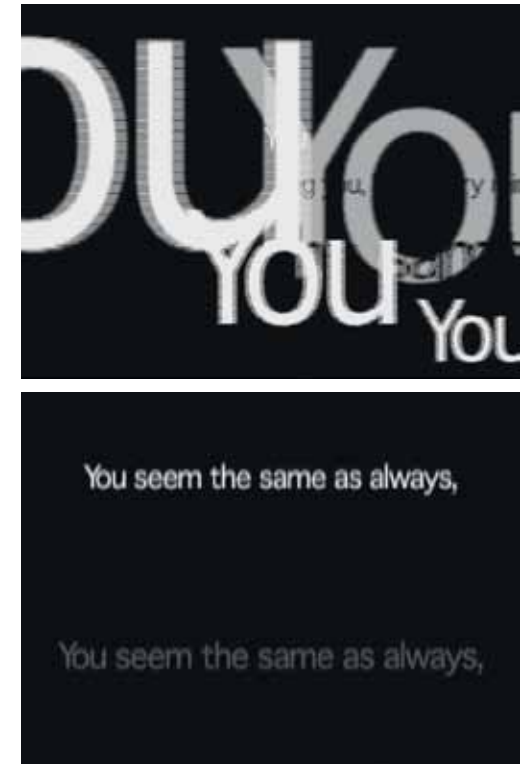

João Leonardo

One Letter from Sol LeWitt



Eric Leiser

Basidiomycota-Agaricomycetes



Michael Lent

no title



Dan Levenson

Swiss Artists



Tan Kwank Liang

East is Red? West is Blue?



Liz Liguori
Dominos



Mauricio Limon
no title

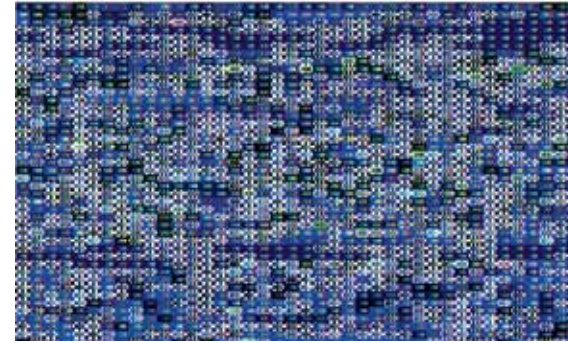

Jung-Hua Liu
Wi-Fi Structures in a Wireless City



Lisa Lok
After Sol LeWitt, Wall Drawing 34A,B,C,D,E,F

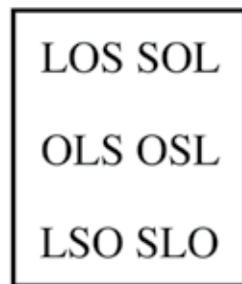

Lucy Lippard
LOSS but still LOL from SLO LL



Rob List
Smoke Drawing



Mark Lomax
Roadworks

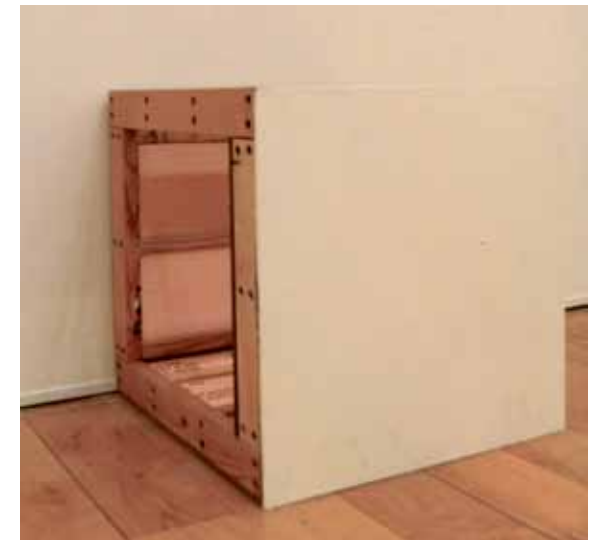

Ron Longsdorf
A Cube for Sol LeWitt

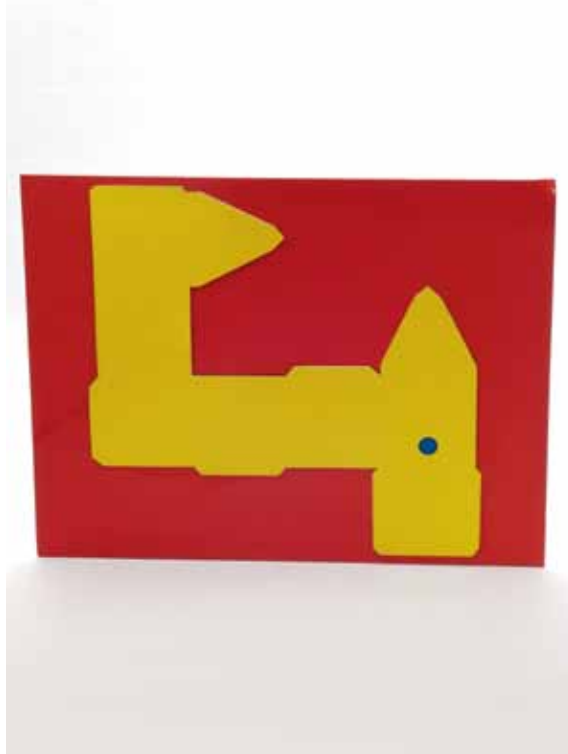

Alex Lopez
Birdhouse



Tom Lovelace
An Exchange with Sol LeWitt and a Stranger



Lauren Luloff
no title



Teodoro Lupo
Rule (Maquette)

propositions for observer:
 think about the existence of this
 part with this thing
 punch this poster
 imagine you made this poster
 don't understand this poster
 be one with this
 spit on it
 touch it
 ignore this poster
 keep thinking what happened

Jonas Lozoraitis
propositions for observer

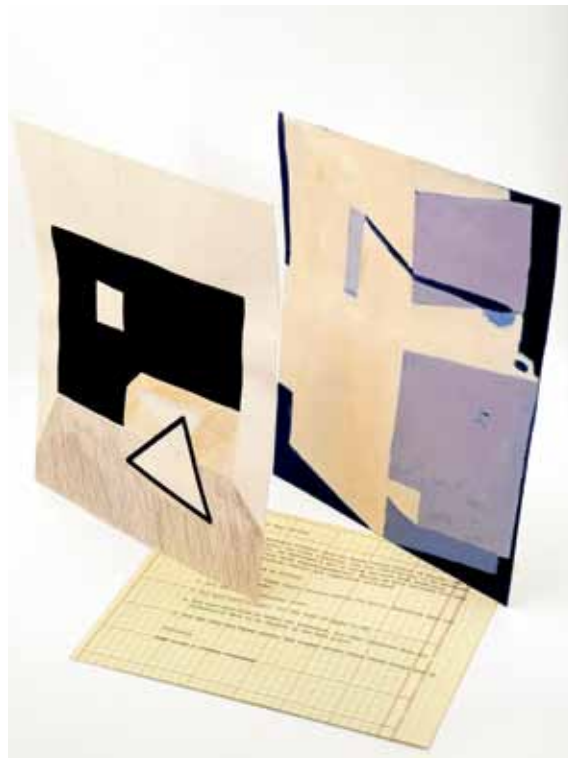

Adam Lucas & Corydon Cowan Sage
no title



LustrousChemistry
*Three Components; a Beginning, a Middle, and an End
(to be used in any order)*



Euan Macdonald
Mosquito Under a Paper Cup

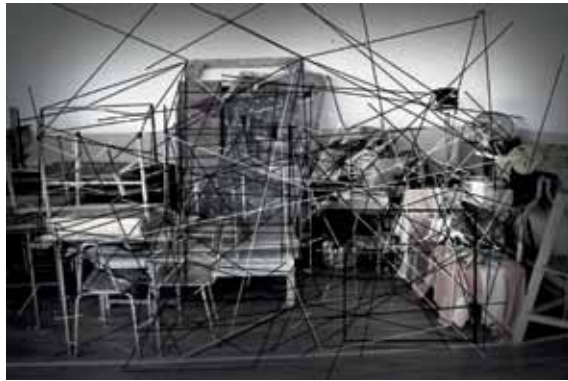

Tatjana Macic
Floating Thoughts, Rhizome and Shapes

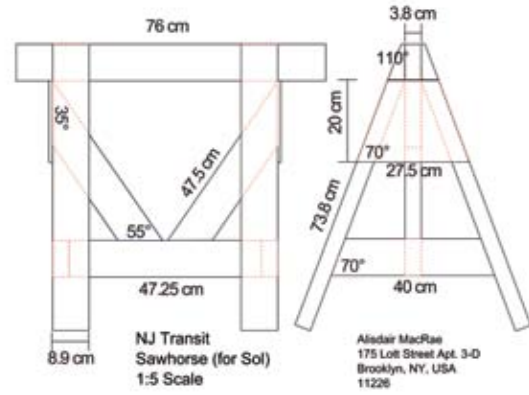

Alisdair MacRae
NJ Transit Sawhorse



Basim Magdy
A Film about the Way Things Are



Moritz Majce
Wall Drawing No. 6



Ian MacIstra
Ekneb Books

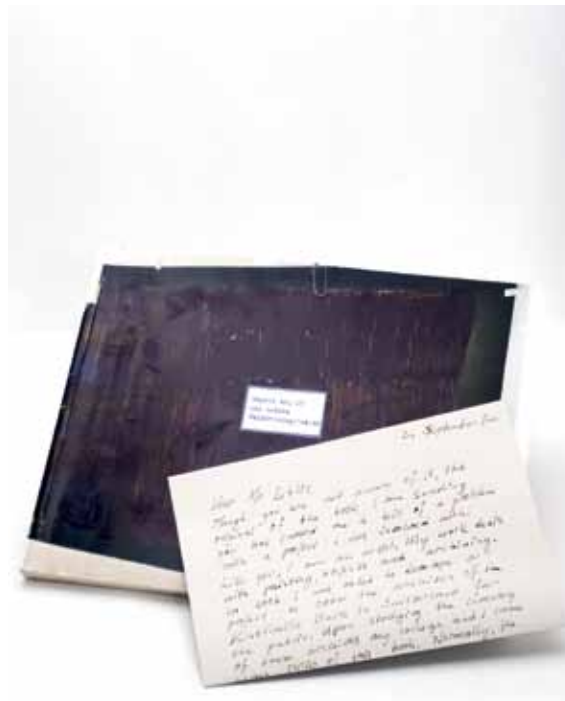

Renée Magaña
no title

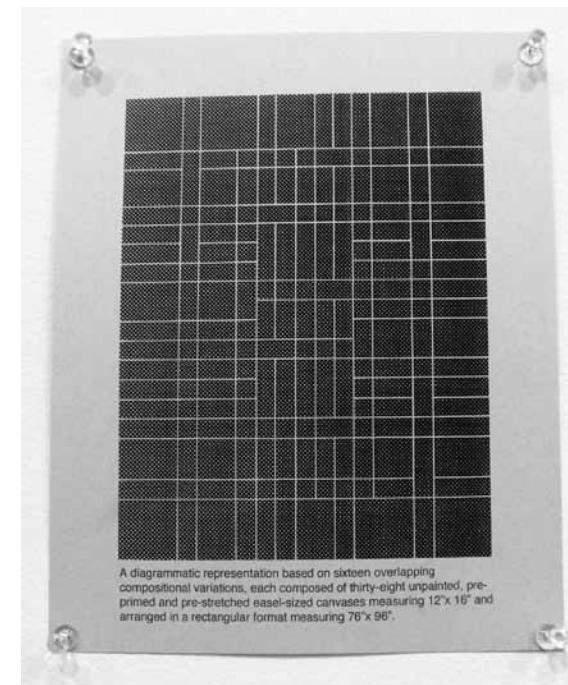

M. Makki
Untitled



Jessie Mann
East Boston Walkway

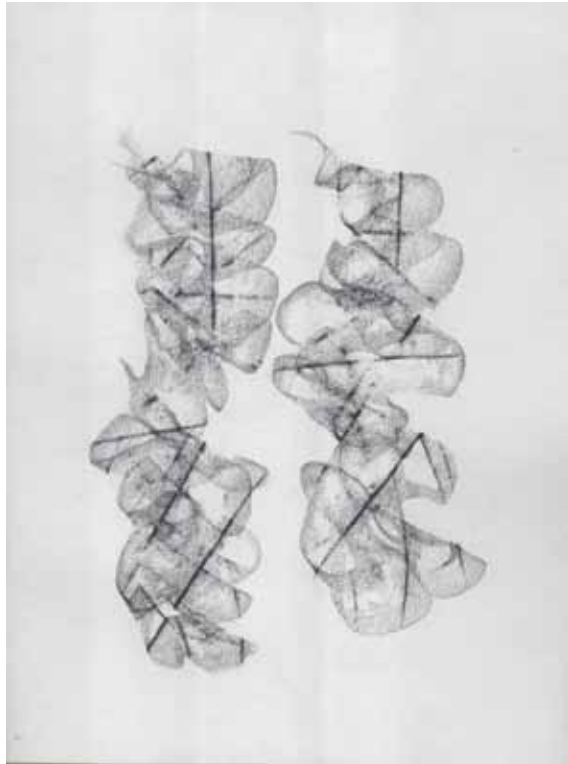

Eva Mantell
Call and Response



Tom Marioni
no title

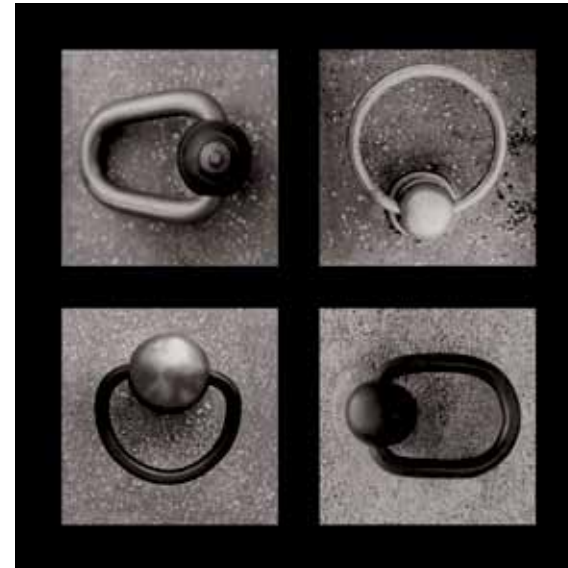

Laszlo Marsch
R.I.P. (Rest in Peace)



Christina Martinelli
Drawing Made While Discussing Drawing with R.P., Nervous



Monika Marklinger
Sometimes I Think That Painting Is The Only Way We'll Have a Revolution



Melissa Marks
Adventures of Volitia: THE REACH



Margherita Marzorati
Movie Intro



Jay Masonek
no title

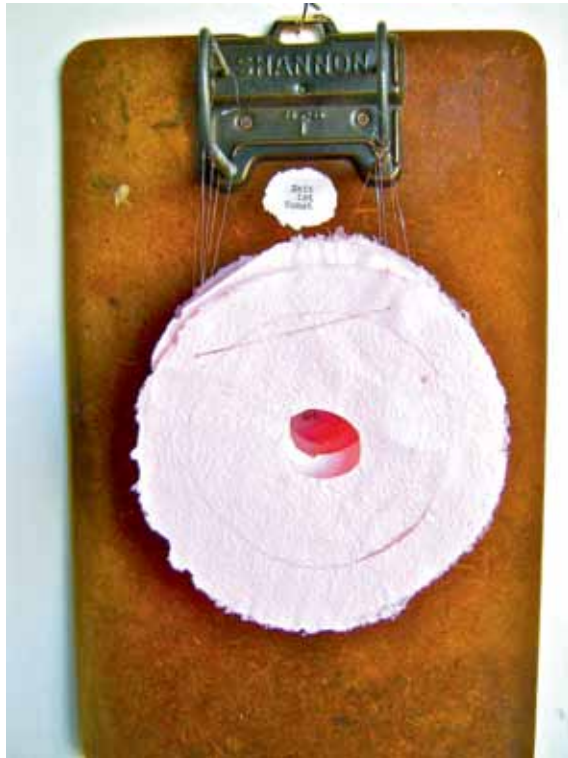

Thelma Mathias
Zeit ist Kunst



Lauren Matsumoto
Mood Triangle



Serena McCarroll
All Citizens



Jeni McConnell
no title



Patrick Maxcy
Preserve

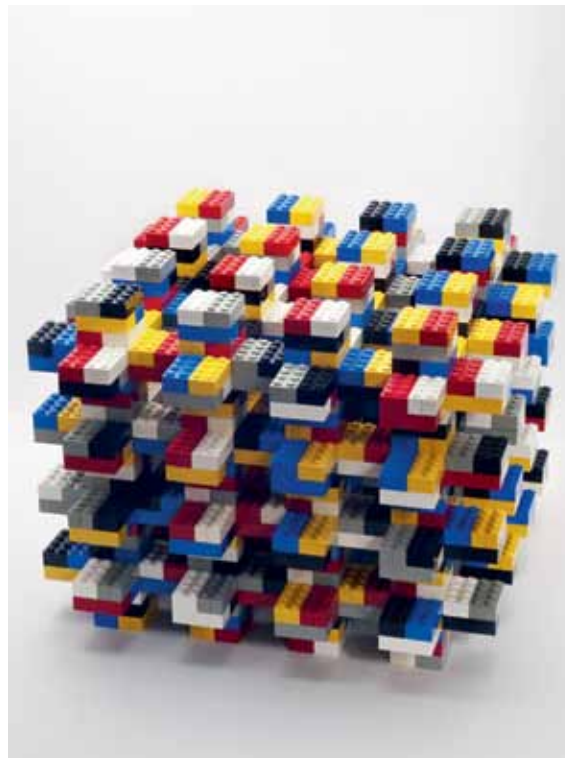

Jackie McAllister
Exchange



Timothy McDowell
A Notebook for Sol



Alexandra McGlynn
Object, Portland Place, London



John McLaughlin
Line Out



Sarah McMenimen
Untitled

Knitting Pattern 56
for Sol LeWitt

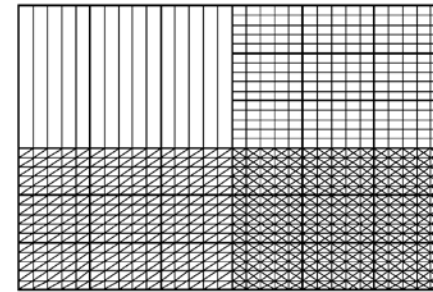

- | | No stitch
- Knit
- ⊠ Knit 2 together
- ⊞ Slip slip knit

Nancy Anne McPhee 2010

Nancy Anne McPhee
LeWitt Knit Pattern



Matthew McQuillan
Untitled



David McNab & Bryan Eccleshall
For Sol: Drawing Conclusions

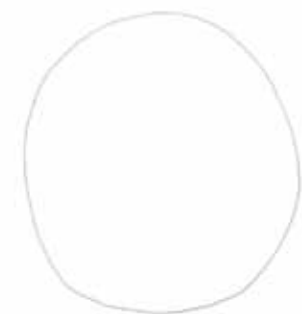

Christopher McNulty
Untitled (2003–2004)



Kathleen McShane
For Sol (and Also Susanna & Carol)

for Sol



Mary-Anne McTrowe
For Sol



Beth Megatulski
Midas Touch



Meryl Meisler
no title



Eric Meltzer
Loss Leader

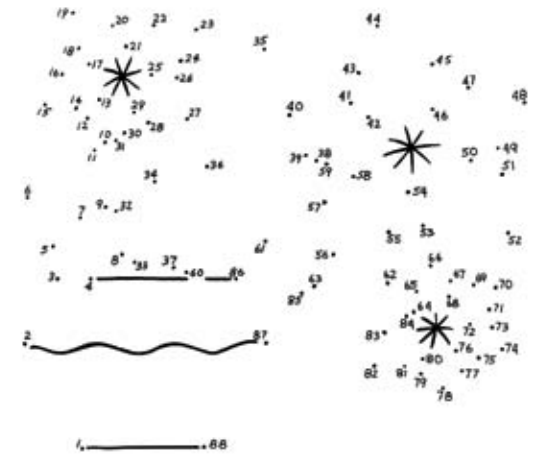

Jason Mena
no title



John Eugene Melecsinsky
Two Minute Gesture Sketch

RECIPE FOR SOL LEWITT

INGREDIENTS

Water
Bouillon Cube

METHOD

The success of this recipe rests on your ability to follow instructions. Start by exchanging 'idea' for 'recipe' and 'art' for 'meal', so that the idea recipe becomes the machine that makes the art meal.

Once you are comfortable with this practical alteration and you are willing to follow irrational thoughts absolutely and logically, begin by filling an exceptionally large pot with water. Bring to the boil. Add a bouillon cube - stirring diligently as the cube dissolves. The meal is now more or less inevitable.

You must now reduce, reduce, reduce. The bare essentials are desirable, and you are doing well if the process has been ludicrously simple thus far.

From here you may want to add other vegetables, high-starch rice or meats - whether it be fish, chicken, pig or cow - yet this step remains outside instruction for the precise reason that it is optional, and therefore not necessary.

Remain cooking until the meal has been resolved. Remember that the work meal is a permanent installation until it is destroyed eaten.

Serves as many people as possible.

Tom Melick
Recipe for Sol LeWitt

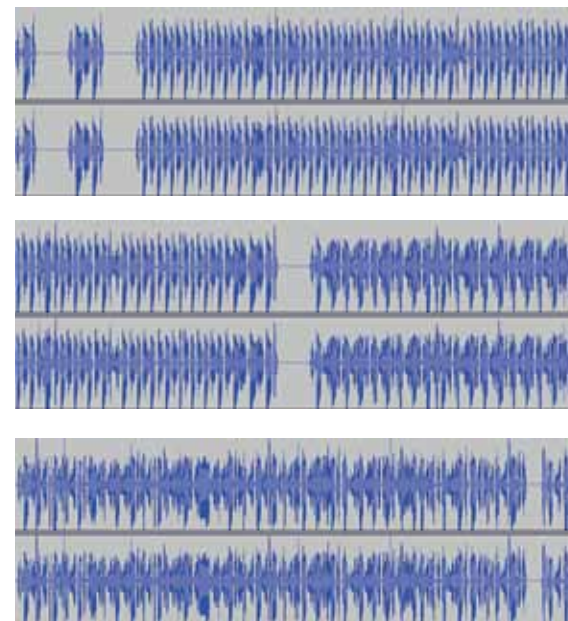

Astrid Menze
Scratch!

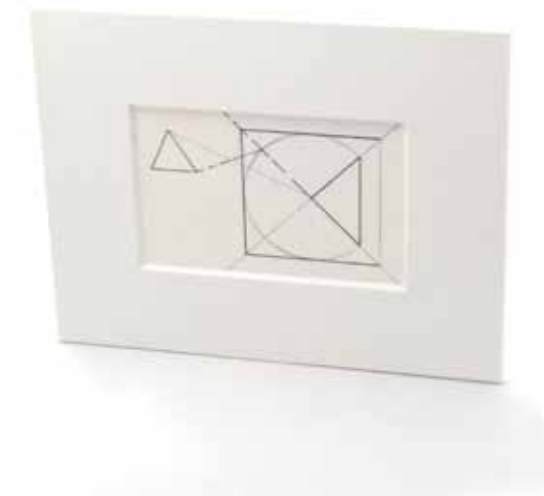

Alejandro Merizalde
no title

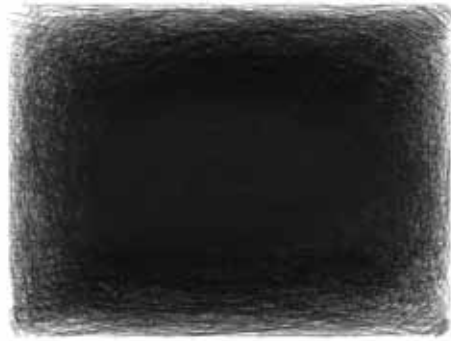

Jon Meyer
One mile long line (drawing tablet and computer software)

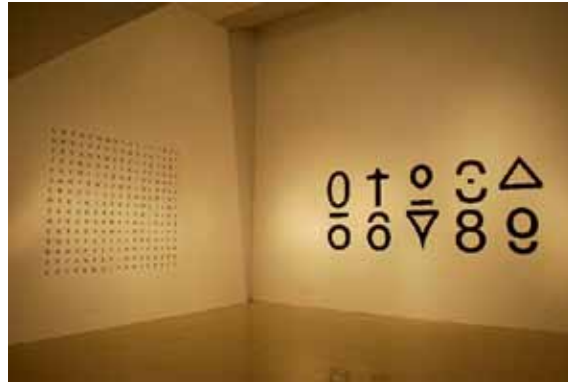

Jane Chang Mi
Rorschach 0-9



Hye-Ryoung Min
no title



Louisa Minkin
no title



Marina Miletic
Off the Wall



Bradley Miller
Dusk

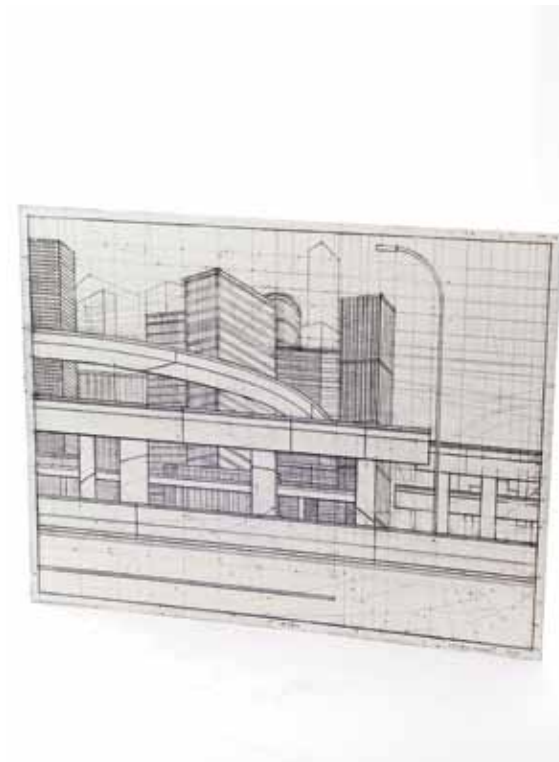

Stephen Mishol
Weft



Benjamin Mitchell
Bless This House



Eileen Starr Moderbacher
Home

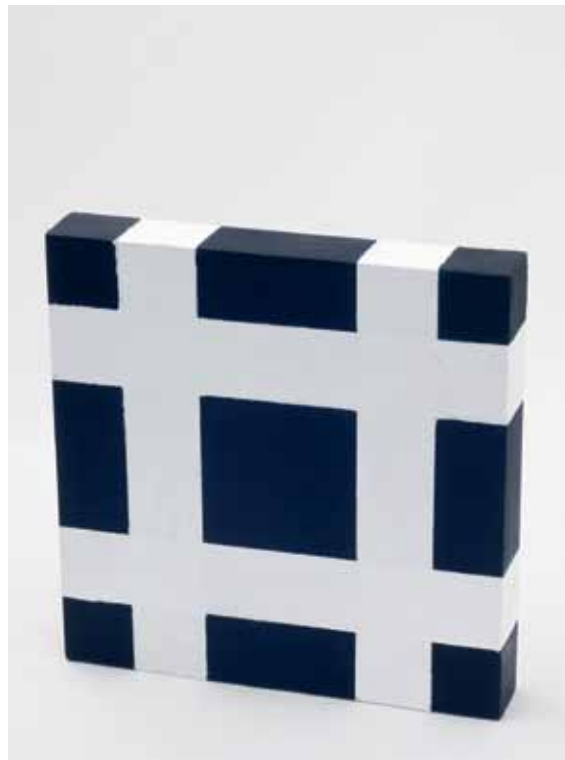

Jose Molestina
After Sol LeWitt Wall Drawing 614



Robert C. Morgan
2 Word Poem



Michael Morrill
Dear Lawrence No. 5

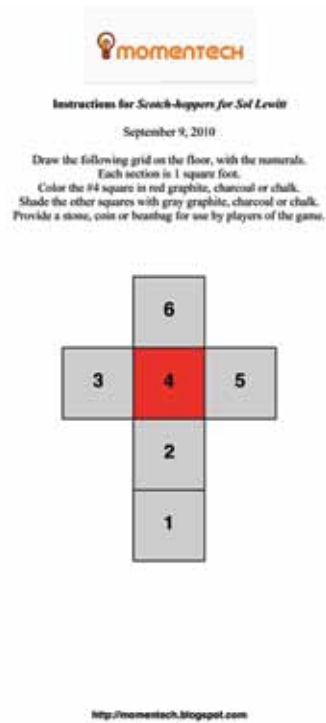

MomenTech
Scotch-hoppers for Sol LeWitt



Young Min Moon
44 Saints



Kate Morrison
Cubix



Judd Morrissey
no title



LeWitt / Morrissey
Image of Sol LeWitt's work on the wall and Leo Morrissey's work on the column in the *SITTINGS* exhibition at SECCA, Southeast Centre for Contemporary Art, Winston Salem, NC in 2008.



Nicole Mortiboys
Specialist Saw



Andy Moxon
Leith Scotland 2010

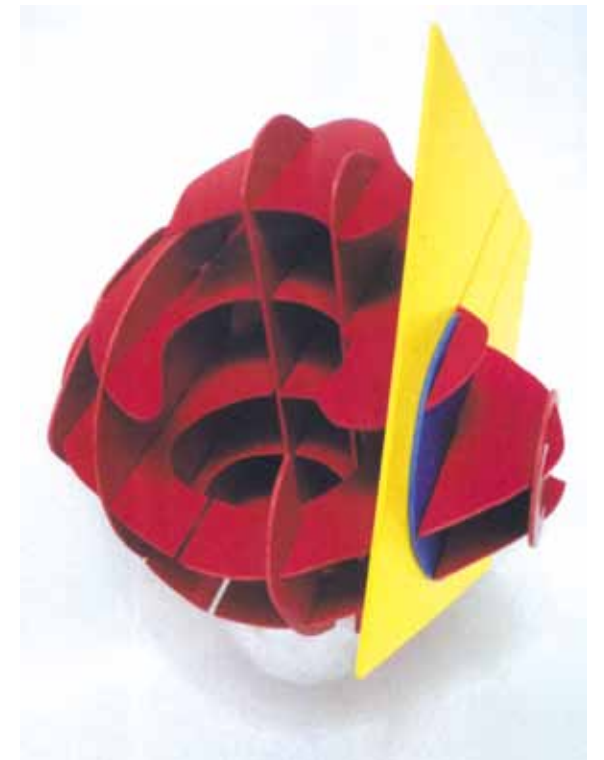

Tiki Mulvihill
Lessons from Sol

Leo Morrissey
Documentation of Trajan Revisited



Arezoo Moseni
An Exchange with Sol LeWitt



Mariella Mosler
no title



Ana Hadzi Muratovic
ALT



Liz Murfitt
TRUTH



Shea Naer
Untitled



Yoshi Nakama
Thank You Sol



Mary Nash
Twin Worlds



Cherilyn Naughton
Parallel Realities Vol II



Lisa Nankivil
no title



Lisa Nanni
Space Projectile

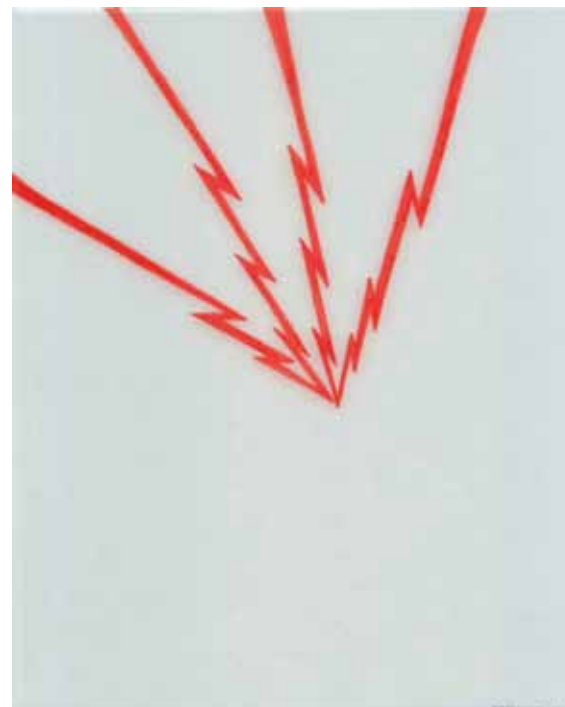

Terry Nauheim
HEAR Cok, OK BATISTA!

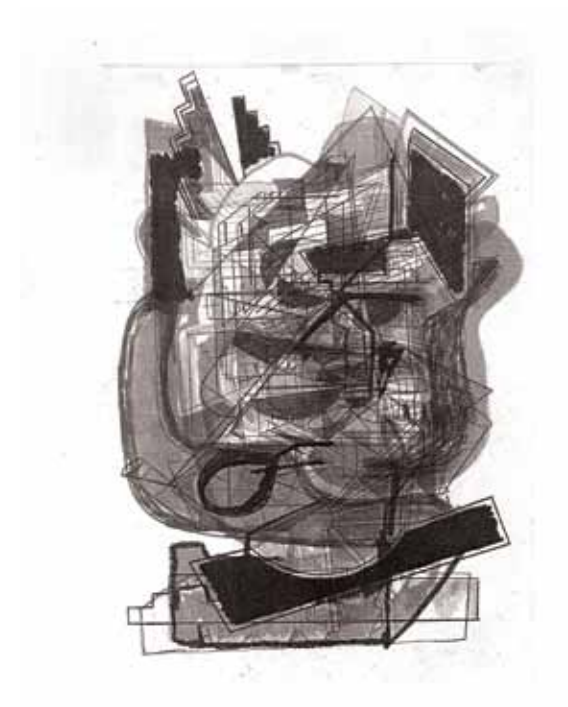

Toony Navok
Infrastructure Drawing



Lilo Nein
TRANSLATE YOURSELF! A Performance Reader for Staging / SELBST ÜBERSETZEN! Ein Performance Lesebuch zum Aufführen



Cristina Neves
View 8#



Chee Wang Ng
Rice Bowl Homage to Sol LeWitt



Matt Niebuhr
Untitled (Karma, Sol LeWitt, Letting Go)

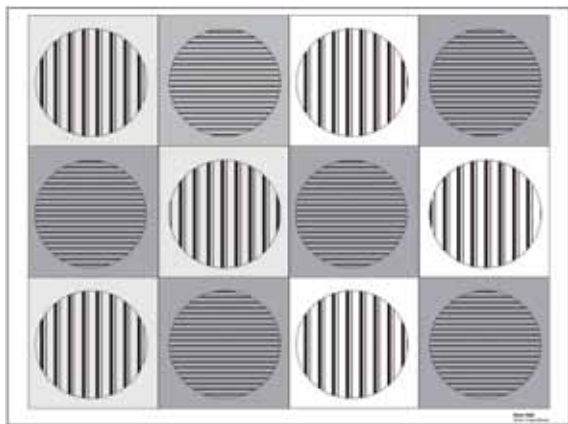

Paula Neves
Snow Wall



Laura Newman
Untitled

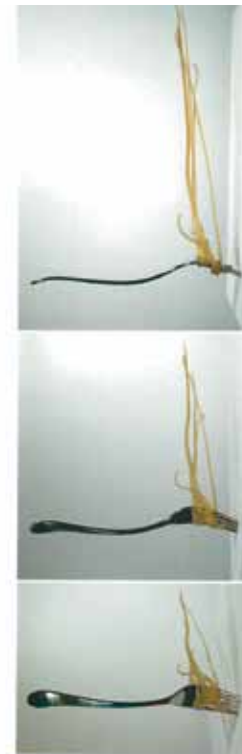

Adam Niklewicz
Calle Lunga



Justin Nissley
Untitled



Rose Nolan
A Big Word - HELLO



Minou Norouzi
I Remember



Miika Nyyssonen



Anne O'Callaghan
You Can't See the Forest for the Trees



Bob Nugent
no title



Kristen Nyce
Linguahedron (Prototype)

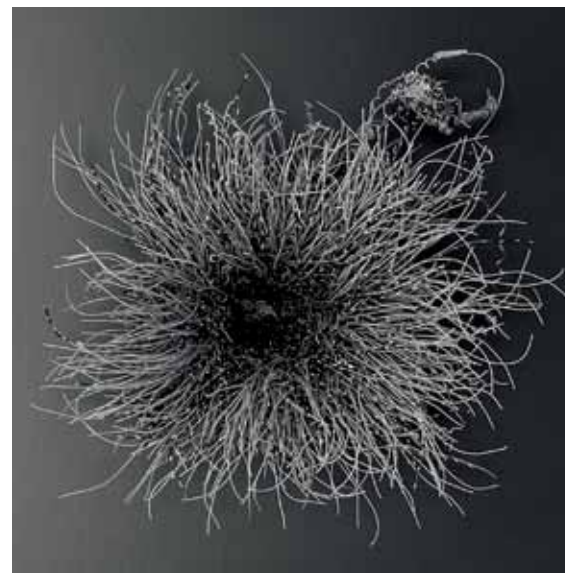

Amanda Oliphant
Still from DVD



Juan Olvera
400 Lines for Sol LeWitt



Anselm Orasch
Triptychon

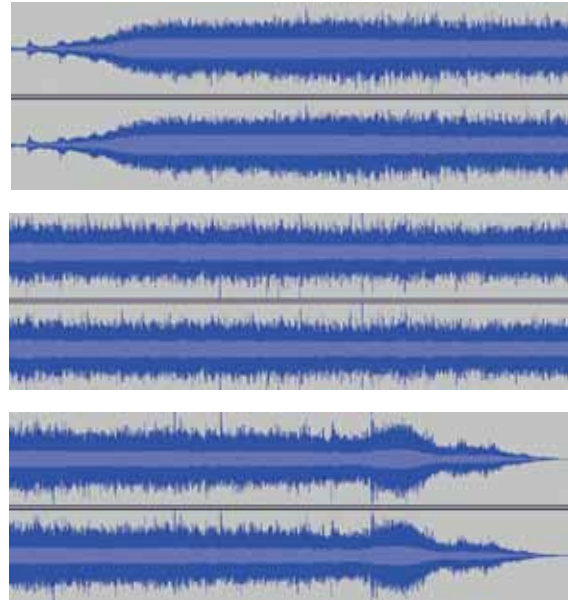

Ela Orleans
Amsler Grid

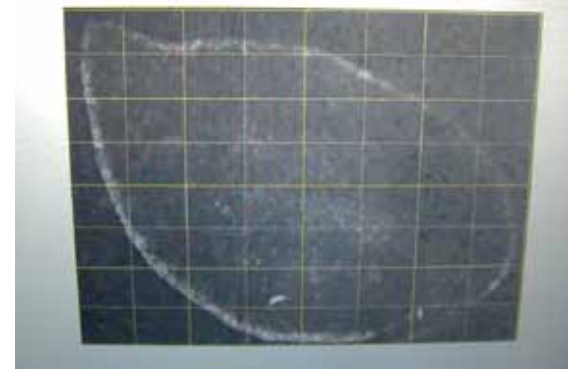

Jurgen Ots
Timeline

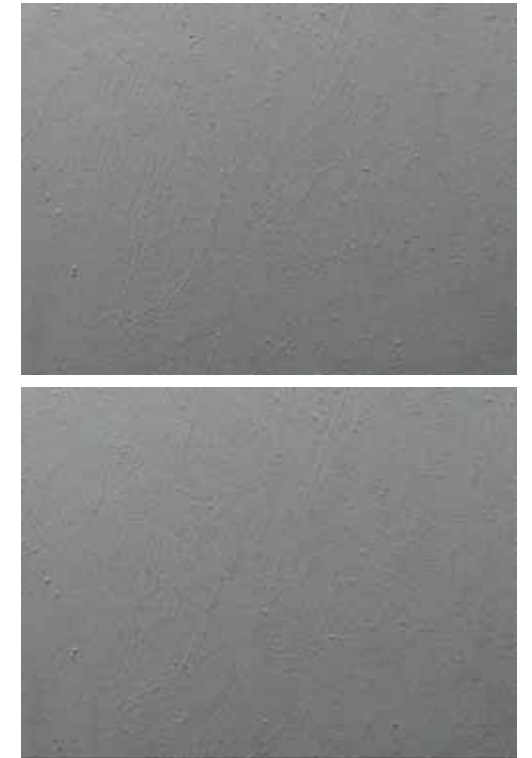

Kjell Otterness
4' 33" Soul Cone



David Oswald
Colorful Squares



Yukimi Otagiri
Diary of a Housekeeper



Kenji Ouellet
Self, Cinema No 1



Adrienne Outlaw
no title

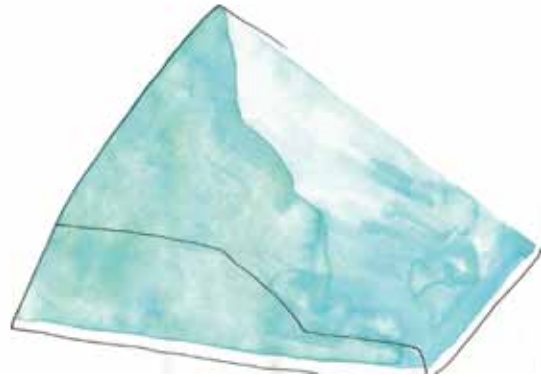

Barbara Assis Pacheco
California Sea Lion (for Sol LeWitt)



Scott Page
Abandoned Bookshelf



Salvatore Panatteri
Untitled (Incandescent)



Jared Pappas-Kelley
no title



Cristina Palacios
PACHA



Kirsten Palz
Object #6—to Be Sent Overseas



Lilia Papperini
no title



Sjoerd & Laura Paridaen
Correspondence

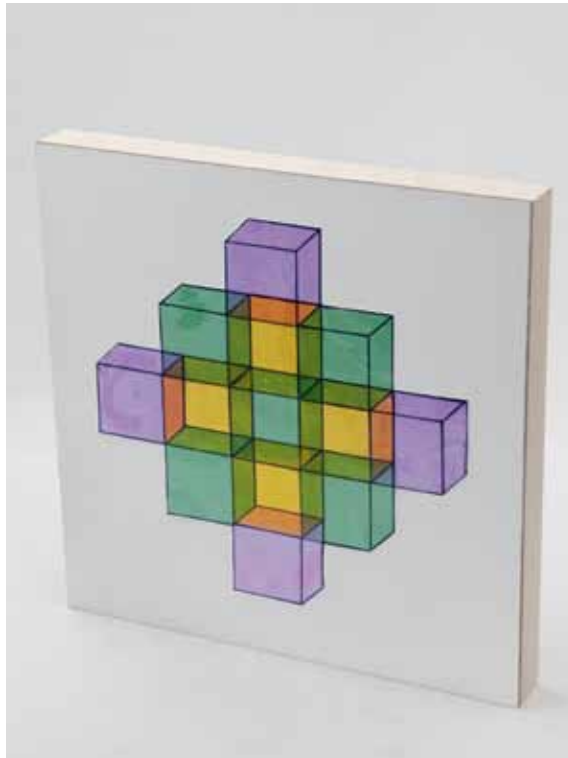

Seongmi Park
After Sol LeWitt, Wall Drawing 610



Roula Partheniou
100 Variations (excerpt)

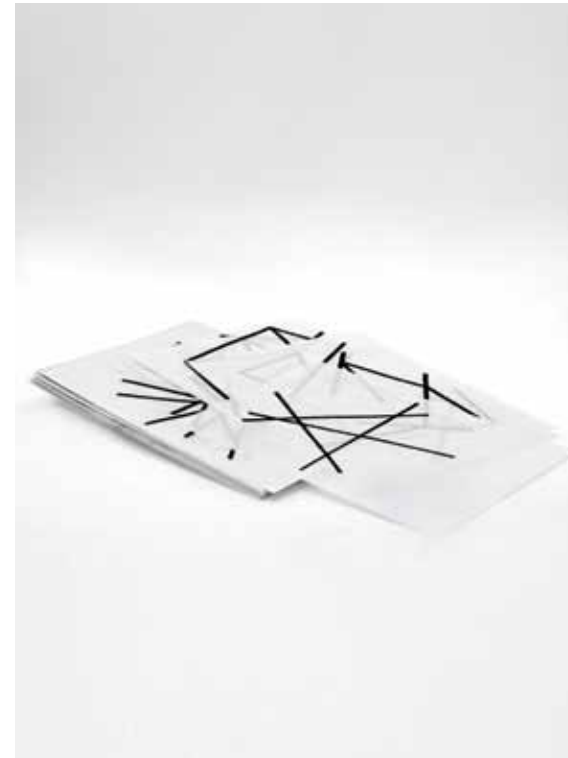

Adria Pecora
Excerpt from the Series "nets" (for Sol LeWitt)



Rachel Peddersen
Timecard: 06.17.08; Timecard: 05.26.08

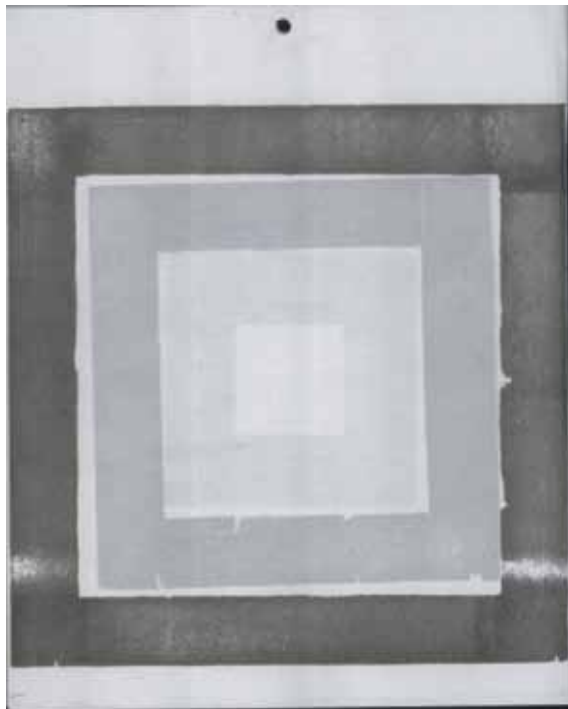

Chloe Pascal
Not Titled



John Pearson
Yorkshire Series: Regeneration Continuum: SLW2010



Haavard Pedersen
You Went Out Last Night

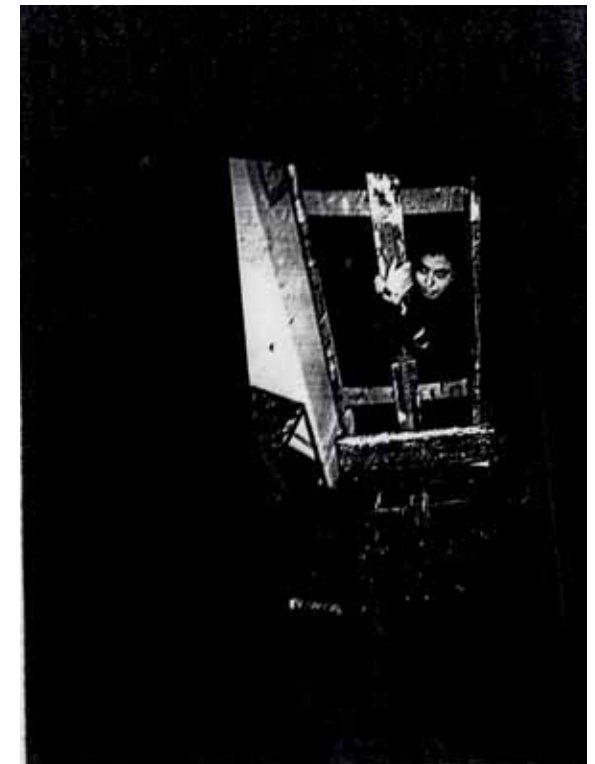

Leemour Pelli
Clinging for Dear Life



Jenny Perlin
From *Ending and Altered* (It should run its course.)



Jaime Permuth
"Untitled" (Question with no answer)



Alan Phelan
Cabbage



Hattie Phillips
Untitled 1

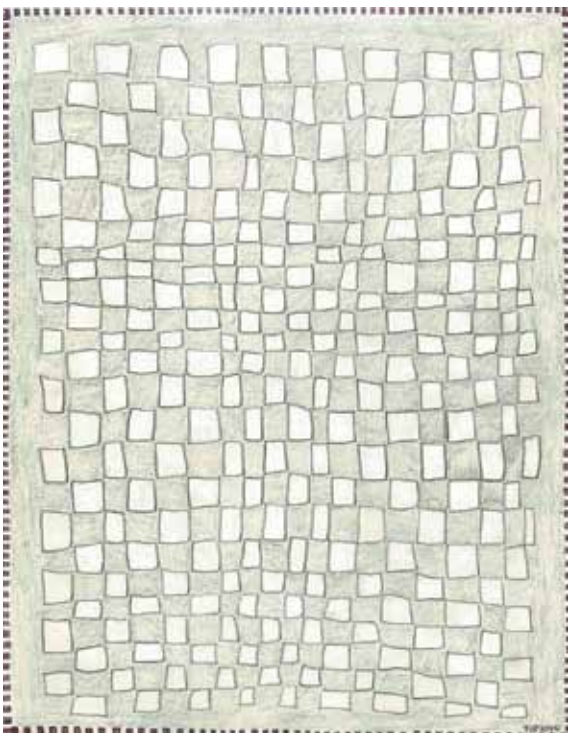

Tessa Perutz
For Sol LeWitt



Eva Petric
Star Pulsating

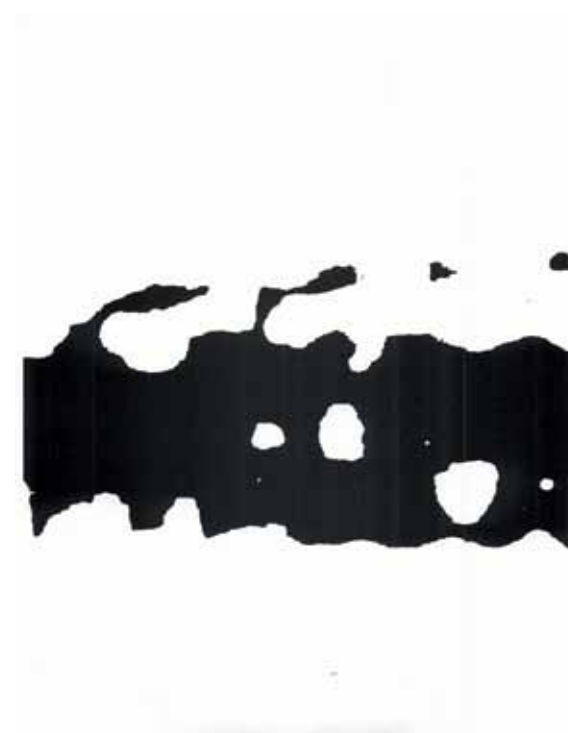

Noah Phillips
no title



Andrea Pinheiro
Reykjavik Palette-Safn-Miniature



Nikholis R. Planck
no title



Mel Prest
no title



Dustin M. Price
You Cannot Halve Infinity



David Procnuiar
Black and White School for Sol LeWitt



Franklin Preston
no title



James Prez
no title

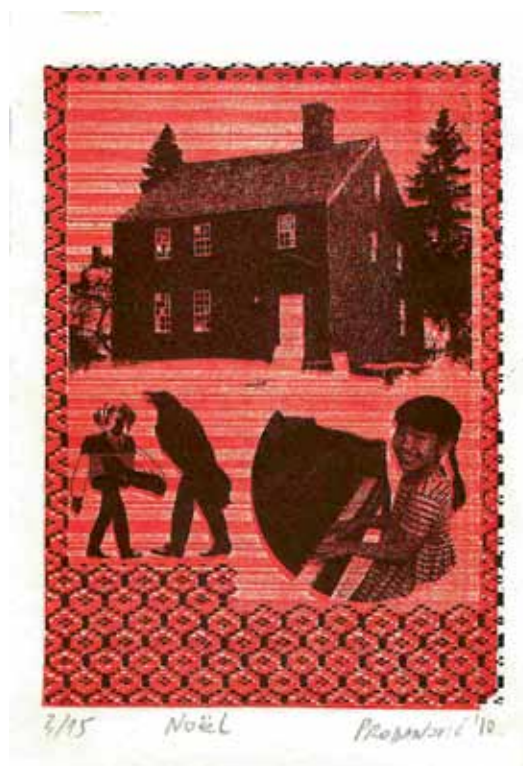

Sejma Prodanovic
Noel

An Exchange with
SOL LEWITT



curated by Regine Basha
TWO PARTS
MASS MOCA 22 - JAN - 31 MARCH 2011
CABINET 20 JAN - 19 FEB 2011

Michael Raaum
Sol Was



Ross Racine
no title

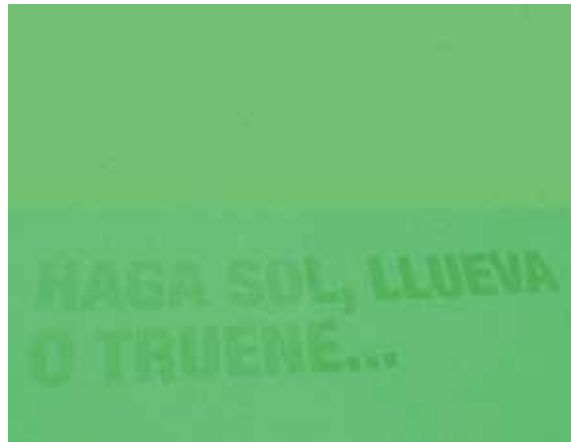

Nora Raggio
Haga Sol, Lluve, O Truene



Paul Ramirez Jonas
Boarding Pass



Debra Ramsay
In Half, Twice

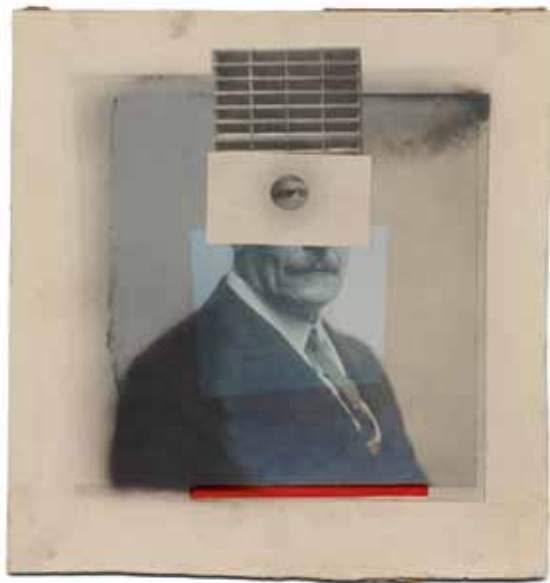

Jared L. Ragland
He Said He Likes to Take It One Thing at a Time

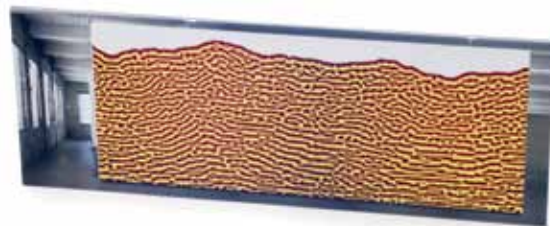

Mischa Rakier
no title



Trish Ramsay
Untitled



Sal Randolph
Language Drawing for Sol LeWitt



Victor Raphael
Postcard from Sol



Ray Rapp
no title

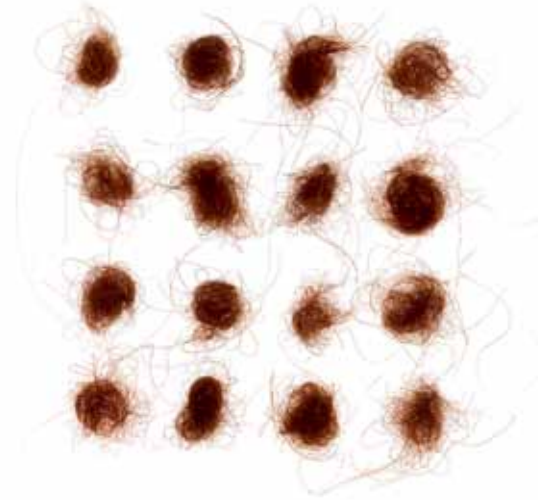

Eugenia Raskopoulos
Grid Hair

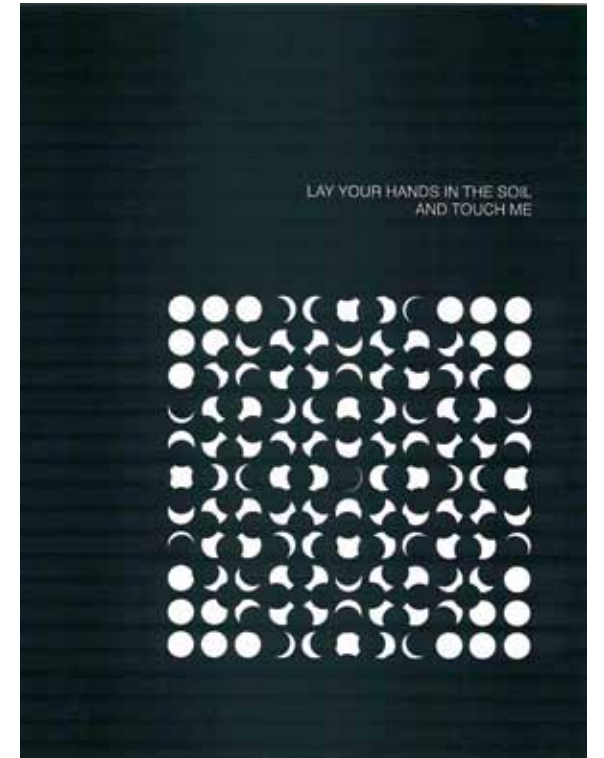

Birgit Rathsmann
Poster 01, 02, 03



Rashanna Rashied-Walker
Turn Your Back On The Sea / Interrupt Sound



Lisi Raskin
Powdered Donuts

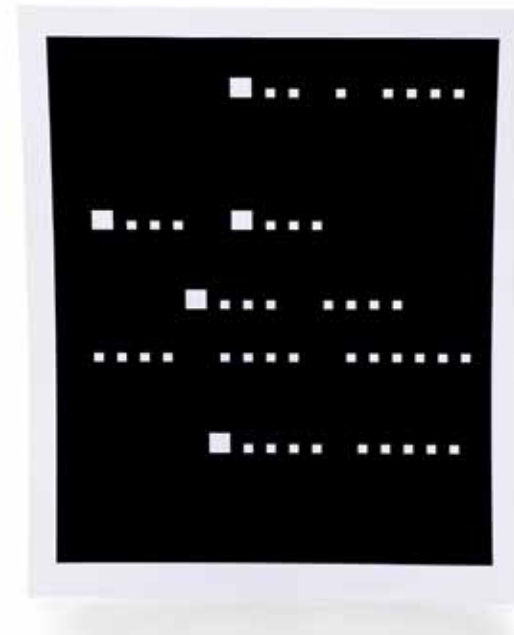

Beverly Rautenberg
Dear John [LETTER]



Lucy Raven
Jain girl whistling in Chennai, India (for Sol)



Chris Rawcliffe
Sol Destroying



Andrea Ray
no title



Gail Rebhan
Some Light Switches in my House



Sandra Rechico
no title



Ben Raynor
Untitled



Xavier Rayuela
balloon drawings



Susan Reedy
Ephemeral Memory 4



Andrea Dasha Reich
Untitled

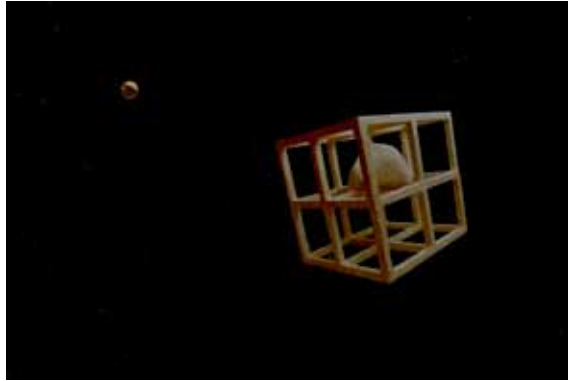

Arnold Reinisch
LeWittite in Space 1



David Rhodes
Untitled 2010

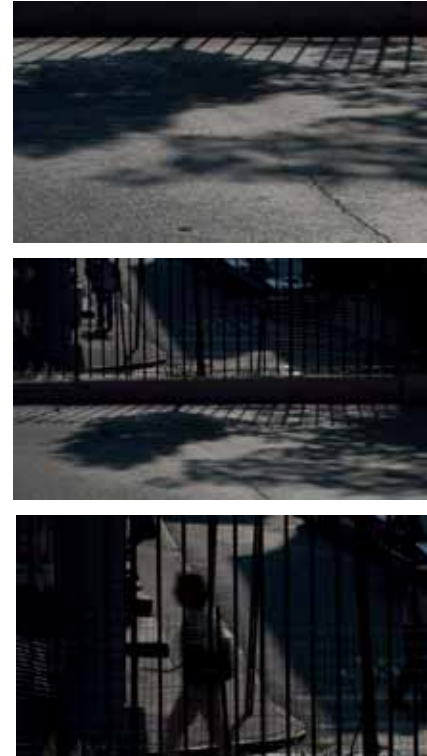

Frances Richard & Shelly Silver (and in absentia, Sol LeWitt & Eva Hesse)
LeWitt Hesse Richard Silver



Lynn Richardson
no title



Vel Riberto
Olana Meadow



04. Angelo Ricciardi: Song for Sol, 2010

Angelo Ricciardi
Song for Sol

ART IS NOT CRITIQUE ART IS NOT CONCEPT ART IS NOT FORM ART IS NOT INTUITIVE ART IS NOT PROCESS ART IS NOT PROPAGANDA ART IS NOT LOGIC ART IS NOT HISTORICAL ART IS NOT GESTURE ART IS NOT NOTHING ART IS NOT PASSIVE ART IS NOT MENTAL ART IS NOT SURVEILLANCE ART IS NOT PRIVATE ART IS NOT SUBLINE ART IS NOT PACKAGED ART IS NOT INSTITUTIONALIZED ART IS NOT MONUMENTAL ART IS NOT ALLUSION ART IS NOT LANGUAGE ART IS NOT EXPRESSION ART IS NOT REVOLUTIONARY ART IS NOT DEMATERIALIZED ART IS NOT THERAPY ART IS NOT BUREAU ART IS NOT OBJECTIVE ART IS NOT PUBLIC ART IS NOT FEMINIST ART IS NOT FREE ART IS NOT SUBJECTIVE ART IS NOT SUBJECT ART IS NOT INTERVENTION ART IS NOT COMMUNICATION ART IS NOT POLEMIC ART IS NOT S.C.U.M. ART IS NOT INFORMATION ART IS NOT DECONSTRUCTION ART IS NOT SEMBLANCE ART IS NOT MEDIA ART IS NOT ART ART IS NOT MATERIAL ART IS NOT EMOTIVE ART IS NOT UTILITARIAN ART IS NOT PARADOXICAL ART IS NOT EXPERIENCE ART IS NOT ARTFACT ART IS NOT PRETENTIOUS ART IS NOT SIMPLE ART IS NOT BELIEF ART IS NOT ACHIEVEMENT ART IS NOT CANVAS ART IS NOT EXHIBITIONIST ART IS NOT EXPLORATION ART IS NOT WEINER ART IS NOT OELVIE ART IS NOT WORK ART IS NOT SYNTHETIC ART IS NOT METHOD ART IS NOT DISCOLORISE ART IS NOT IMPERATIVE ART IS NOT DESTRUCTION ART IS NOT CATEGORY ART IS NOT VALUE ART IS NOT TECHNIQUE ART IS NOT DECENTERED ART IS NOT STATUS ART IS NOT AUTONOMOUS ART IS NOT DEVOURING ART IS NOT FAG ART IS NOT POWER ART IS NOT LINGUISTIC ART IS NOT COLLECTIVE ART IS NOT PRODUCTION ART IS NOT DISTRIBUTION ART IS NOT SPACE ART IS NOT INTERIOR ART IS NOT IDEOLOGICAL ART IS NOT CONTENT ART IS NOT MECHANISTIC ART IS NOT PHILEMANTIZED ART IS NOT NEGATION ART IS NOT SYSTEMATIC ART IS NOT SEMANTIC ART IS NOT FIGURATIVE ART IS NOT DESIGN ART IS NOT SITUATION ART IS NOT SURVEILLANCE ART IS NOT SAFE ART IS NOT AESTHETIC ART IS NOT ICONIC ART IS NOT GENERALIZED ART IS NOT UNCHANNING ART IS NOT TRUTH ART IS NOT PROPERTY ART IS NOT STRUCTURE ART IS NOT ARCHITECTURAL ART IS NOT PEGMIC ART IS NOT FACT ART IS NOT POLITICAL ART IS NOT COCA—COLA ART IS NOT REDUCTIONARY ART IS NOT ORIGINAL ART IS NOT POP ART IS NOT MASS ART IS NOT SPECTACLE ART IS NOT CHANCE ART IS NOT ABSURD ART IS NOT BEAUTY ART IS NOT PRETEXT ART IS NOT CONTEXT ART IS NOT TEXT ART IS NOT VISUAL ART IS NOT SEX ART IS NOT TUTION ART IS NOT IDEA ART IS NOT NEW ART IS NOT REACTIONARY ART IS NOT FIGURATIVE ART IS NOT DESIGN ART IS NOT FASCISTIC ART IS NOT CONCEPTUAL ART IS NOT MIMETIC ART IS NOT EXPERIMENTAL ART IS NOT AVANT-GARDE ART IS NOT DEAD ART IS NOT MEANING ART IS NOT SOLITARY ART IS NOT SEMIOTIC ART IS NOT DICHOTOMY ART IS NOT FICTION ART IS NOT MEDITATION ART IS NOT ART HISTORY ART IS NOT SIGNIFICATION ART IS NOT GENDER ART IS NOT PARA-ARTISTIC ART IS NOT ONTOLOGY ART IS NOT DESCRIPTION ART IS NOT HUEBLER ART IS NOT STATEMENT ART IS NOT GLOBAL ART IS NOT CULTURAL ART IS NOT EVIDENCE ART IS NOT POST-ART IS NOT DADA ART IS NOT STRUCTURALIST ART IS NOT CRAFT ART IS NOT ACTION ART IS NOT STYLE ART IS NOT PARTICIPATION ART IS NOT EXCHANGE ART IS NOT RUPTURE ART IS NOT AFTERPHILOSOPHY ART IS NOT DISPLACEMENT ART IS NOT IRONY ART IS NOT BEING ART IS NOT SEIGELAUB ART IS NOT ORGANIZED ART IS NOT MEASURED ART IS NOT ANALYSIS ART IS NOT KANT ART IS NOT DOGMA ART IS NOT DOCUMENT ART IS NOT EVENT ART IS NOT MCLUHAN ART IS NOT REDUCTIONIST ART IS NOT JUDGEMENT ART IS NOT CONTRADICTION ART IS NOT CENTERED ART IS NOT OBJECT ART IS NOT ARTIFICE ART IS NOT ALLUSION ART IS NOT ESSENCE ART IS NOT TRACE ART IS NOT BEHAVIOR ART IS NOT INVENTION ART IS NOT MARXIST ART IS NOT COMMERCIAL ART IS NOT SUPPRESSION ART IS NOT GRAHAM ART IS NOT AUTHENTIC ART IS NOT MEDIUM ART IS NOT SREED ART IS NOT MYTH ART IS NOT NARRATIVE ART IS NOT INTERACTIVE ART IS NOT IMITATION ART IS NOT TRANSCENDENT ART IS NOT MIMAMENANT ART IS NOT PLACE ART IS NOT NECESSITY ART IS NOT KNOWLEDGE ART IS NOT REALIZABLE ART IS NOT PRACTICE ART IS NOT ACADEMIC ART IS NOT EXPOSURE ART IS NOT IDENTITY ART IS NOT INFORMATION ART IS NOT COUNTERCULTURE ART IS NOT WILL ART IS NOT ENGAGING ART IS NOT ANTI ART IS NOT MARKET ART IS NOT SERIAL ART IS NOT THEORY ART IS NOT MENTORIAL ART IS NOT GREENBERG ART IS NOT FITSCH ART IS NOT CULTURE ART IS NOT ISM ART IS NOT ABSTRACT ART IS NOT PURE ART IS NOT THEOLOGICAL ART IS NOT APPROPRIATION ART IS NOT POSSESSION ART IS NOT PURPOSE ART IS NOT REFERENCE ART IS NOT WRITTEN ART IS NOT CREATIVE ART IS NOT NATURE ART IS NOT VOGUE ART IS NOT DISCIPLINE ART IS NOT CHANGE ART IS NOT HEALING ART IS NOT MORAL ART IS NOT AQUINAS ART IS NOT ENTERTAINMENT ART IS NOT INQUIRY ART IS NOT GUERRICA ART IS NOT NUDE ART IS NOT RELATIVIST ART IS NOT MODERNITY ART IS NOT FOUR CAULT ART IS NOT INDIVIDUAL ART IS NOT PARRHESIA ART IS NOT INTERPRETATION ART IS NOT CLASS ART IS NOT MARK ART IS NOT HIGH ART IS NOT BODY ART IS NOT COMMODITY ART IS NOT HUMAN ART IS NOT ABSOLUTE ART IS NOT SACRED ART IS NOT PIS ART IS NOT CHRIST ART IS NOT MASTURBATORY ART IS NOT EGO ART IS NOT REPRODUCTION ART IS NOT ACTIVISM ART IS NOT DESENSITIZED ART IS NOT WAR ART IS NOT TOURISM ART IS NOT VOYEUR ART IS NOT REBELLION ART IS NOT DEATH ART IS NOT RAPE ART IS NOT LOVE ART IS NOT PATRONAGE ART IS NOT ARCHIVE ART IS NOT OEDIPUS ART IS NOT UNCONSCIOUS ART IS NOT PRIMITIVE ART IS NOT CAPITALIST ART IS NOT DIFFERENCE ART IS NOT MEMORY ART IS NOT VIDEO ART IS NOT IMPRESSION ART IS NOT BEAUBOURG ART IS NOT TABLEAU ART IS NOT DUCHAMP ART IS NOT DESIRE ART IS NOT SCALE ART IS NOT ORGAN ART IS NOT SEXUALITY ART IS NOT HOLES ART IS NOT SUBLIMATION ART IS NOT REALITY ART IS NOT TRANSITION ART IS NOT BECOMING ART IS NOT INSURRECTION ART IS NOT CIRCUMFLEXION ART IS NOT GOOD ART IS NOT BRETON ART IS NOT LIPPAUD ART IS NOT NEUROTC ART IS NOT PSYCHOLOGY ART IS NOT INCERSTUOUS ART IS NOT ANTIBREDETERMINEREALIZATION ART IS NOT PERVERTED ART IS NOT MANIFEST ART IS NOT TERROR ART IS NOT SELF-CRITICISM ART IS NOT CONCEALMENT ART IS NOT ROMANTICIZED ART IS NOT GANGLING ART IS NOT MANY THINGS ART IS

Josué Rivera
Lines on Art

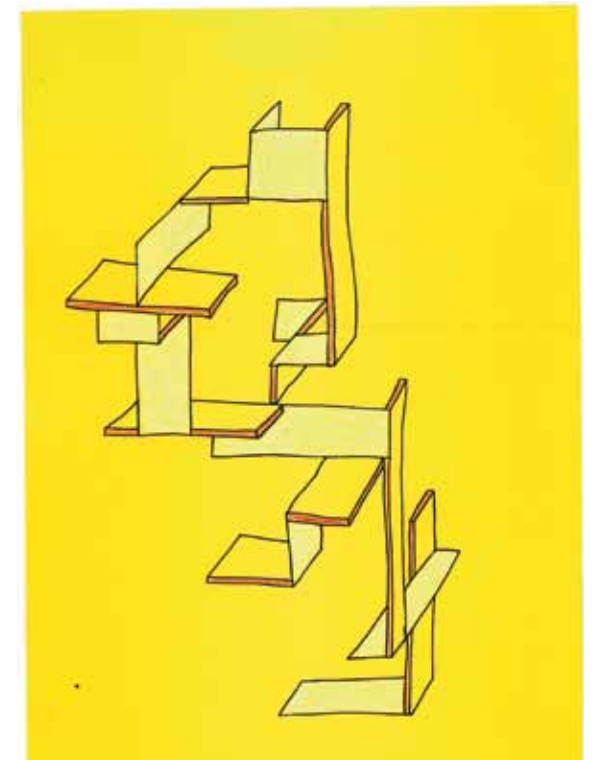

Dai Roberts
UNIT Drawing 51

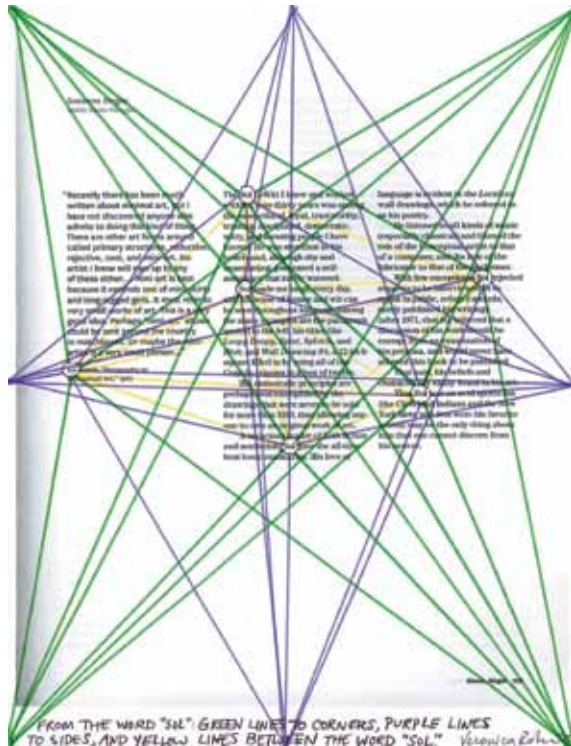

Veronica Roberts
From the Word "Sol": Green Lines to Corners, Purple Lines to Sides, and Yellow Lines between the Words "Sol"



steve roden
3 part variations +1



Taney Roniger
Reckonings Series



Brian Rosa
We All Own the Mona Lisa



Ana João Romana
Despertar Carlos Paredes Coimbra 1925 - Lisboa 1994



Vincent Romaniello
Pink Slip



Matthew Rose
Dumb Bunny



Rhoda Rosenberg
White Line



Carol Simon Rosenblatt
Red Squares with Plants

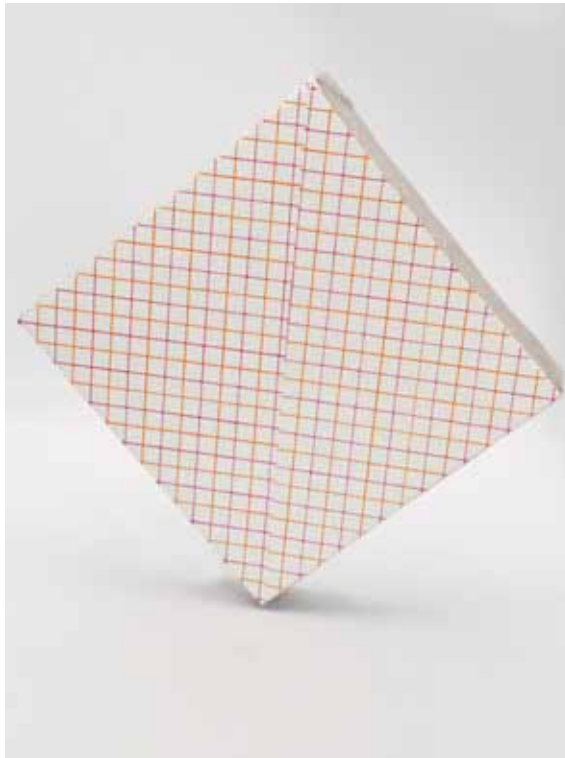

Barbara Rosengarth
Pli 1209



Marie Roux
Future Kit



Philippe F. Roux
Segment of Wall with Space Included



Lisa K. Rosenstein
Revolution



Jessica Deane Rosner
Parallelogram



Andrea Rubio
After Sol LeWitt, Wall Drawing

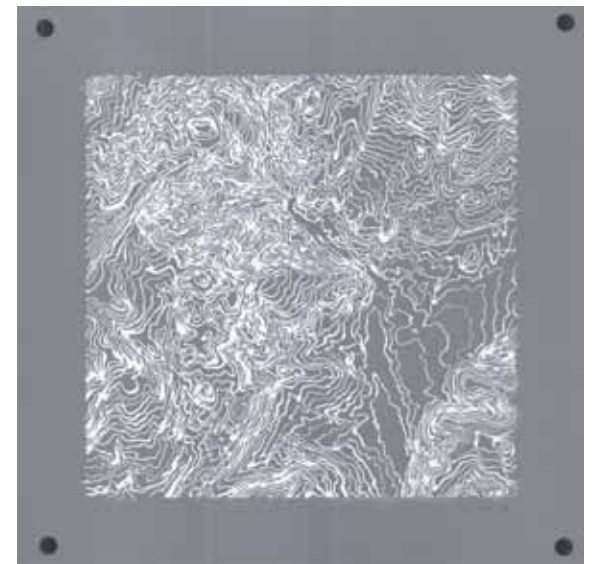

Donna Ruff
Raton SW



Judy Rushin
no title



Carmelle Safdie
Will I Grow Up to Paint a Square?

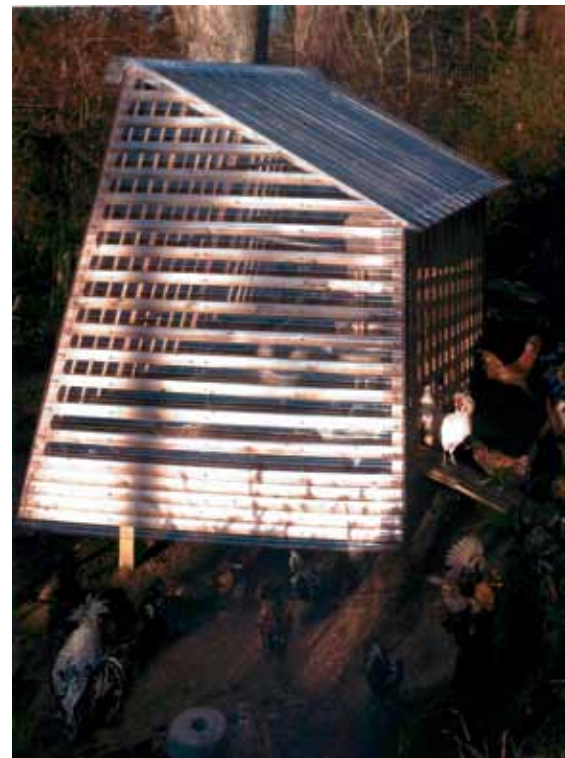

Hope Sandrow
Coop LeWitt



Raphy Sarkissian
For Sol LeWitt, after Rosalind

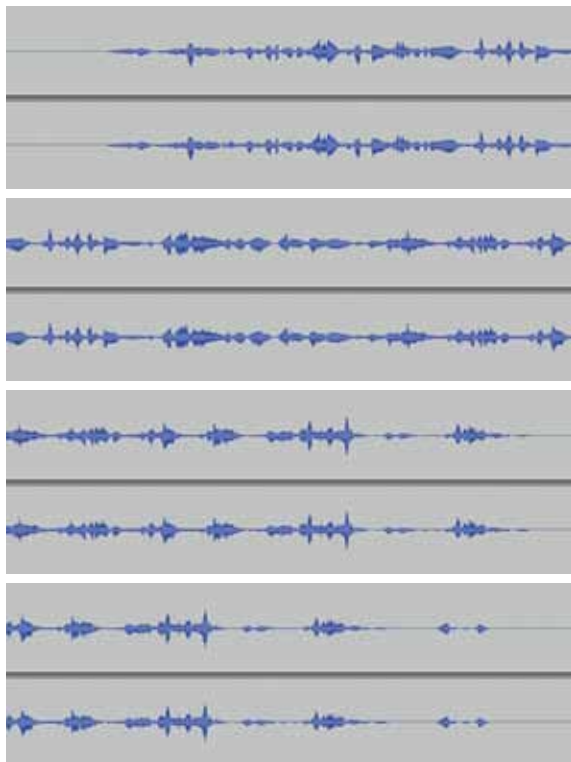

Veronica Sahagun
Weavings



Agatha Salvatierra
Ceci n'est pas un escalier.



Rui Sasaki
Intimate Space



Antje Sauer
Spring

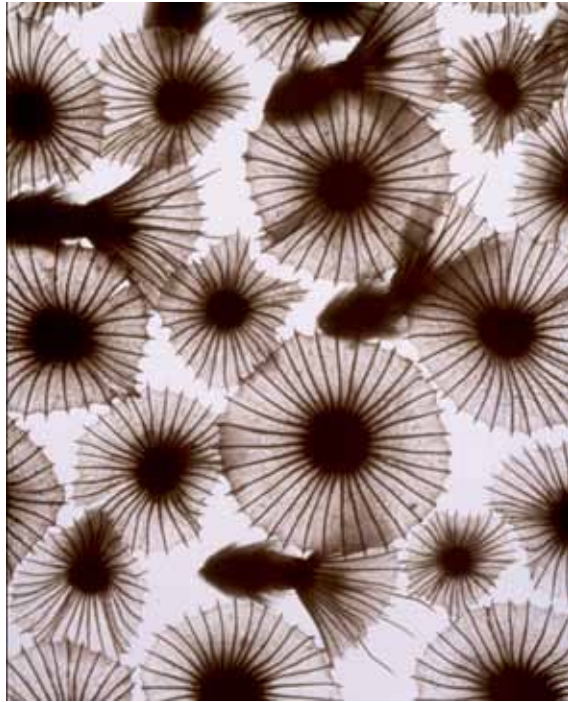

Ron Saunders
Reverse Pincushions

She pulled text from text
 exchanging, changing, alternating, interchanging, trading, marketing, demonstrating, seeking, recording,
 separating, obliging, treating, fleeing, separating, promoting, recognizing, handling, focusing, providing,
 compelling, requiring, observing, correlating, pairing, creating, maintaining, dividing, peeling, sliding,
 perceiving, transferring, shifting, capturing, seeking, serving, making, using, rolling, pointing,
 designing, displaying, showing, including, reflecting, ensuring, dividing, using, covering, sliding,
 measuring, holding, holding, processing, repeating, making, connecting, creating, providing, connecting,
 using, measuring, dividing, connecting, affecting, reducing, providing, differentiating,
 reflecting, correlating, trading, providing, reducing, involving, repeating, accepting, supporting,
 getting, ensuring, working, sharing, containing, appearing, reducing, exhibiting, producing,
 showing, defining, observing, behaving, assessing, handling, containing, leaving, helping,
 suggesting, changing, serving, containing, using, visiting, recording, creating, using, repeating,
 making, handling, lifting, receiving, using, connecting, repeating, reflecting, differentiating, sharing, adapting,
 showing, holding, holding, comparing, connecting, accepting, affecting, reaching, improving, varying,
 maintaining, getting, using, placing, separating, dividing, pairing, dividing, getting, using, using, using,
 dividing, creating, using, visiting, transporting, separating, dividing, reflecting, sharing, adapting,
 making, sharing, using, holding, using, using, using, using, using, using, using, using, using,
 showing, serving, repeating, repeating, displaying, including, looking, making, making, making, making,
 following, leading, walking, stepping, creating, making, approaching, using, creating,
 handling, using, creating, using, providing, handling, creating, sharing, showing, providing,
 using, introducing, acquiring, processing, containing, holding, conducting, teaching, teaching,
 organizing, defining, widening, expanding, rolling, finishing, increasing, multiplying, adding,
 dividing, pulling, calculating, filtering, cleaning, creating, using, paying, receiving, creating, adding,
 applying, recording, using, comparing, finishing, using, providing, creating, serving, making,
 repeating, containing, including, improving, using, getting, taking, packing, collecting, packing,
 filling, making, creating, reflecting, withdrawing, dividing, decreasing, diminishing, leaving,
 leaving, withdrawing, leaving, adding, separating, handling, creating, using, creating,
 attending, improving, adding, making, making, repeating, varying, separating, serving, repeating,
 using, connecting, repeating, sliding, leaving, leaving, creating, using, repeating, creating,
 processing, holding, using, dividing, processing, providing, using, creating, holding, paying, buying,
 collecting, applying, keeping, receiving, processing, handling, varying, creating, making, holding,
 using, using, paying, buying, creating, creating, including, creating, repeating, dividing, rolling,
 forming, connecting, handling, including, displaying, displaying, connecting, creating, making,
 applying, decreasing, comparing, comparing, repeating, creating, affecting, connecting, holding,
 paying, using, holding, processing, manufacturing, producing, following, shaping, representing,
 processing, dividing, making, making, processing, using, holding, leaving, dividing, processing,
 using, making, increasing, including, including, making, creating, making, displaying,
 organizing, organizing, dividing, finalizing, depicting, replicating, screening, illustrating, setting,
 illuminating, achieving, pushing, making, processing, processing, processing, following, providing,
 pulling, performing, paying, following, making, creating, including, paying, making, keeping,
 comparing, handling, using, packing, creating, creating, making, using, creating, getting,
 becoming, including, creating, creating, packing, including, dividing, using, using, using,
 making, making, leaving, suggesting, pointing, leaving, following, representing, decreasing,
 decreasing, increasing, copying, decreasing, pulling, dividing, placing, holding, placing, rolling,
 creating, creating, making, creating, leaving, leaving, taking, taking, using, using, using,
 creating, increasing, creating, using, leaving, processing, including, keeping, using, including,
 including, creating, increasing, leaving, including, leaving, using, leaving, creating, using,
 using, using, creating, creating, making, leaving, leaving, leaving, leaving, leaving, leaving,
 using, using, creating, creating, making, leaving, leaving, leaving, leaving, leaving, leaving,
 processing, processing, filtering, creating, creating, including, including, including, including,
 reflecting, including, using, creating, dividing, creating, using, using, processing, creating, leaving,
 providing, including, leaving, creating, using, using, using, using, using, using, using,
 increasing, including,

Claudia Sbrissa
She Pulled Text from Text



Karen Schifano
Study for a Proposition...



Mary Schilero
A Dip for Sol

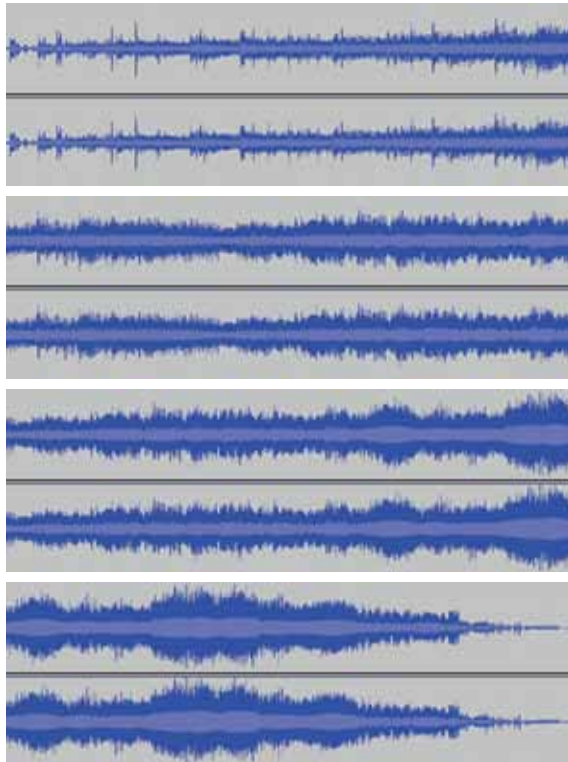

David Schafer
Sentences on Conceptual Art (remix)



James Schaffer
City Flight

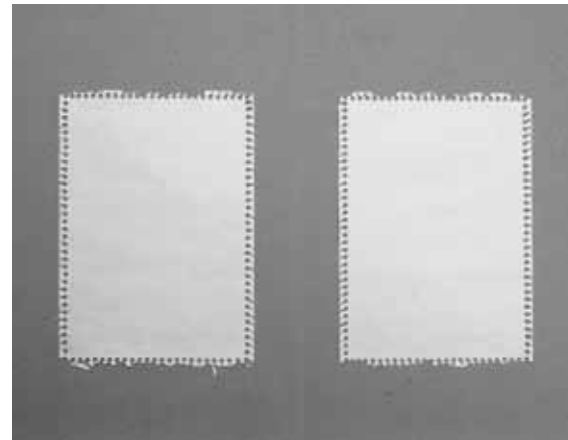

Sarah Schlenker
Ausreisser



Cecilia Schmidt
Migrating Birds



Ginger Scott
NSCAD Litho #148 halved - Sol LeWitt

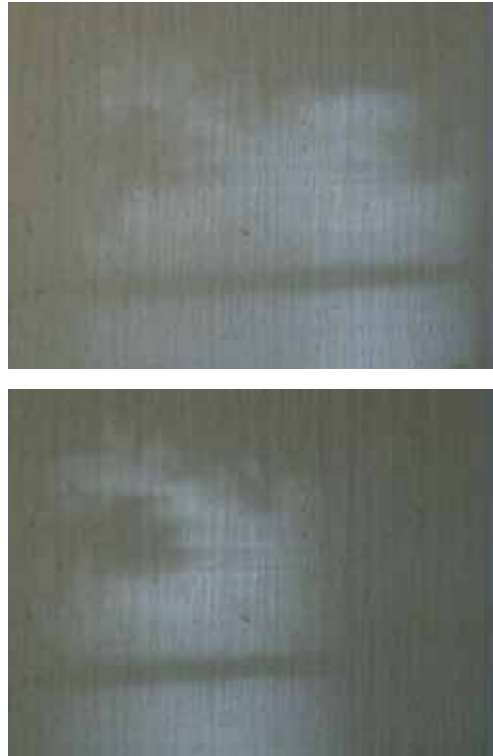

Marcia Scott
La Jalousie for Sol LeWitt



"the undulating land"
- Samuel Beckett, Molloy

Two equally populated ensembles, one quiet tone per player.
Tones last the length of a full exhale, bow stroke or decay.
Separated by a space, the ensembles form a line, arranged side by side.

The outermost player from each ensemble plays, beginning together.
Whenever a tone ends within an ensemble, the inner neighbor plays.
This continues until the innermost player from each ensemble has played.

A pause.

The innermost player from each ensemble plays, beginning together.
Whenever a tone ends within an ensemble, the outer neighbor plays.
This continues until the outermost player from each ensemble has played.

Sam Sfirri, 2009

Nina Servizzi
Untitled

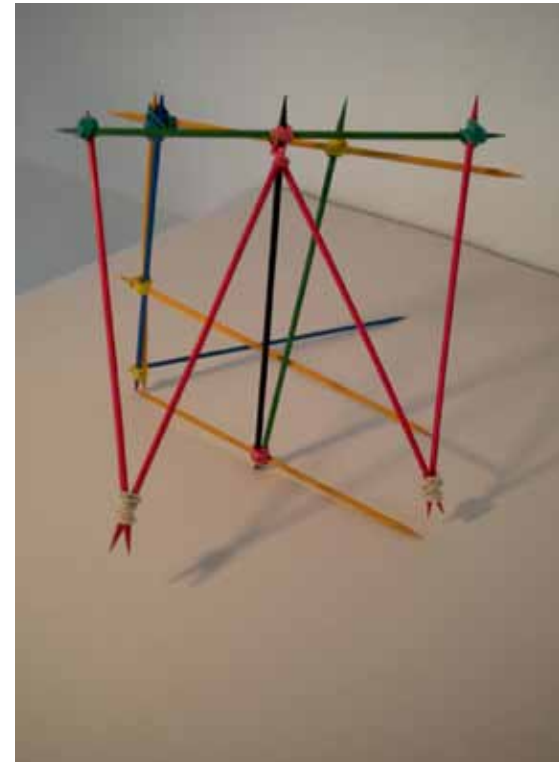

Rose Shakinovsky
L.E.W.I.T.T. Wall Drawing 1 (13 kebab sticks)

Samuel Sfirri
The Undulating Land



Dee Shapiro
For Sol LeWitt



Scott & Skúta
Endless Soup



Antonio Serna
Room to Share



Yi Sheng
Hikaru Dorodango (a mud ball for Sol)



Jieun Shin
Proxy



Peter Simensky
Froebel's Third Gift (Gabe) for Sol LeWitt



Linda Simmel
Sea Lines



Lisa Sigal
Line Up



Suzanne Silver
Gift for Sol LeWitt

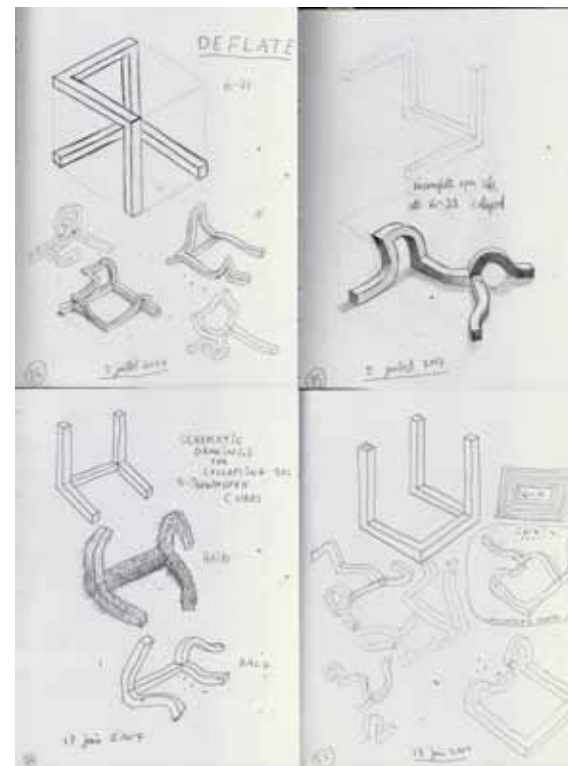

Eric Simon
4 Incomplete Open Cube Sketchbook Drawings



Judith Simonian
Stolen: Never Seen the Light of Day Painting



Nina Slejko
Eating, after Satie

JPG
DVD
CD's

Nataliya Slinko
Unsolicited



Susannah Slocum
Experimental Brick, Laredo Texas 2010

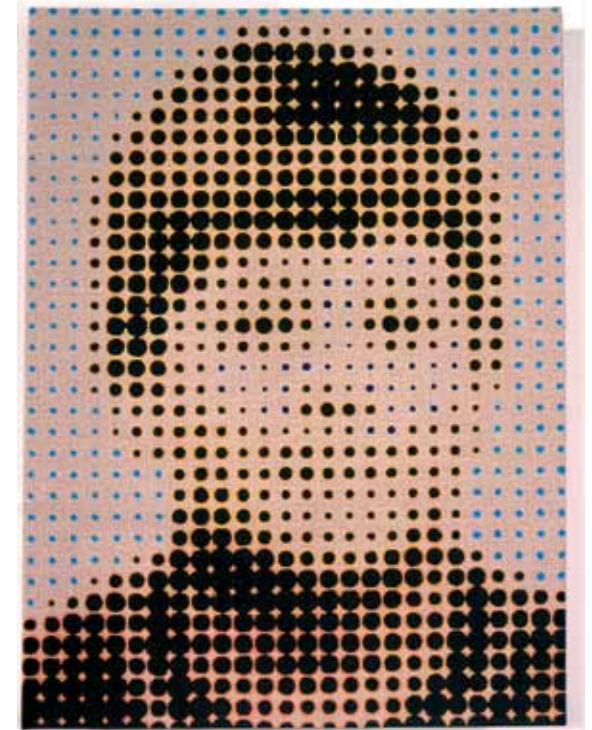

Ana Sluga
no title

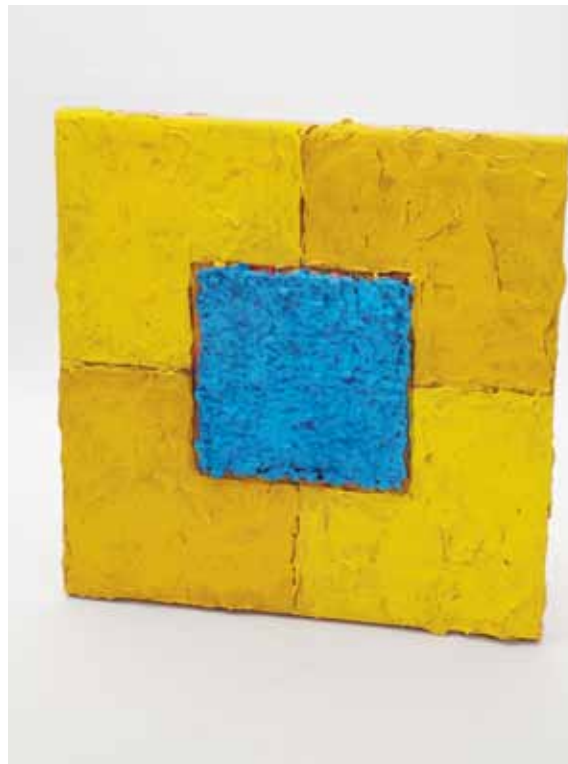

Louise P. Sloane
NinexNein—YellowAqua

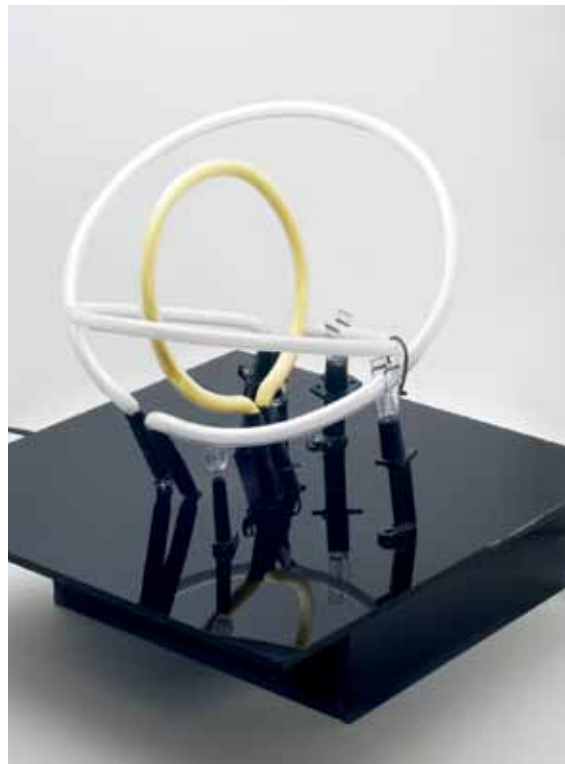

Ben Sloat
CYMK (for Sol LeWitt)

EXPERIENCE

The Finest in
Agrarian Living

TOUR
COTTON, TOBACCO &
RICE PLANTATIONS

BUY
Delicious
Home Cured Hams
& Local Produce

CHAMPE SMITH

Champe Smith
no title



Damon Smith
Black Forms: For Sol LeWitt



Lucas Soi
Untitled



Joel Soliven
no title

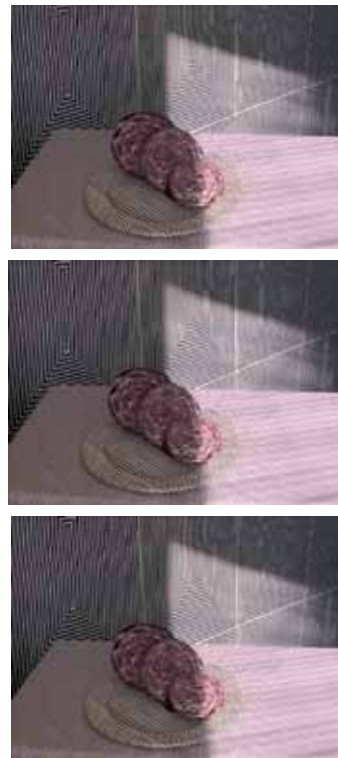

Natalie Sorenson
A Still Life That Cannot Be Pictured



Manuel Sosa
Untitled (Bottle with Paper)



Ted Somogyi
no title

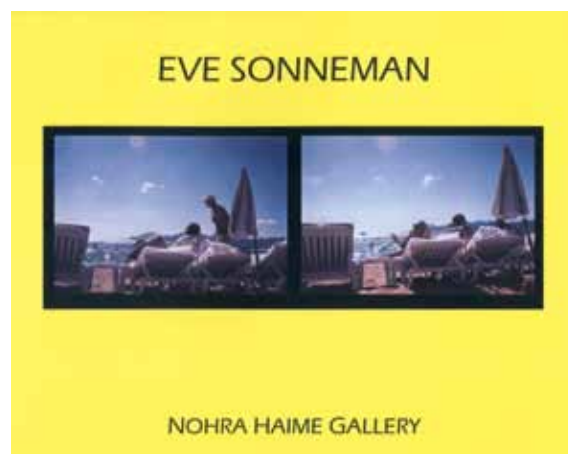

Eve Sonneman
La Cote D'Azur



Milena Sosa
Untitled

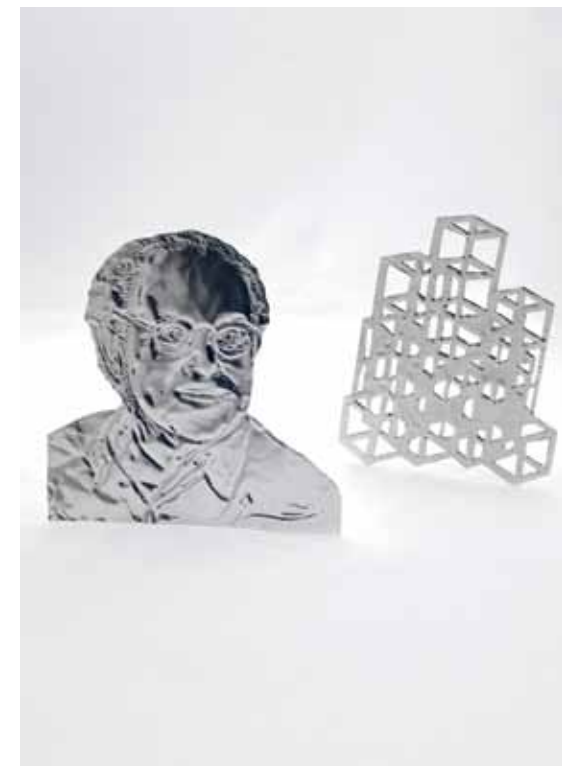

Edra Soto
Soto Sol



Mariangeles Soto-Diaz
Sticky Impermanence (for Sol LeWitt)



Joyce Speechley
A Life's Vision



Malin Ståhl
The Characters



Wim Starckenburg
The Unknown Gallery (Homage to Sol)



Deanna Sperrazza
Inspired by Wall Drawing 614



Janet Stafford
New York Earth

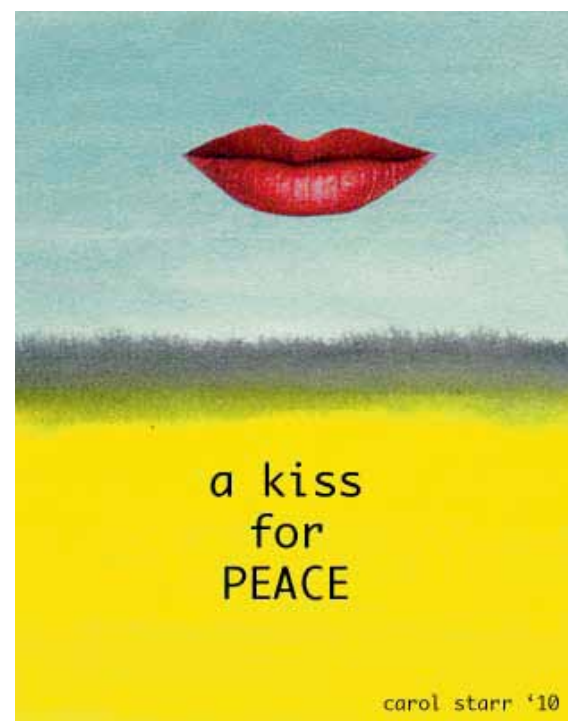

Carol Starr
A Kiss



Roderick Steel
no title



Oona Stern
no title



Sam Still
10/1/10 7:37

Happy Anniversary, Randi.



Love, Yuri

Yuri Stone
Sol's Gift



Lars Strandh
no title



Nico Stock
Intersection



Tim Stoelting
151 Drawings



Ray Stratton
Fortune's Tell



Holly Streekstra
Mustache Comb



Rebeca Stumm
Burials



Diana Sugar
no title

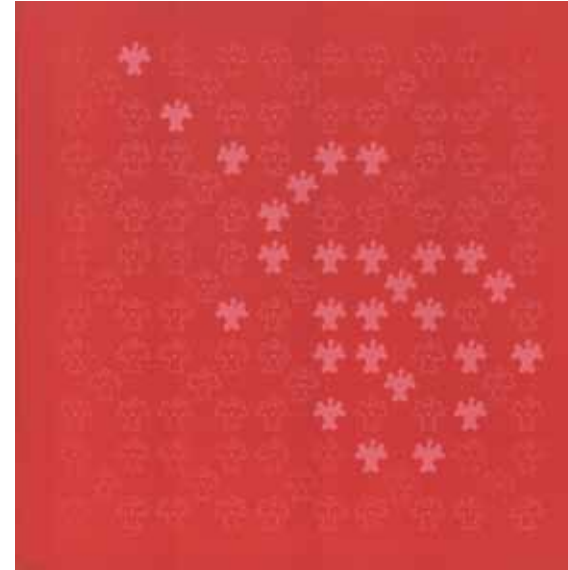

Kelvin Tan Ke Yun
3 Works on Board



Gloria Tanchelev
Open on All Sides



Terry Surjan
A Planet for All SOLs

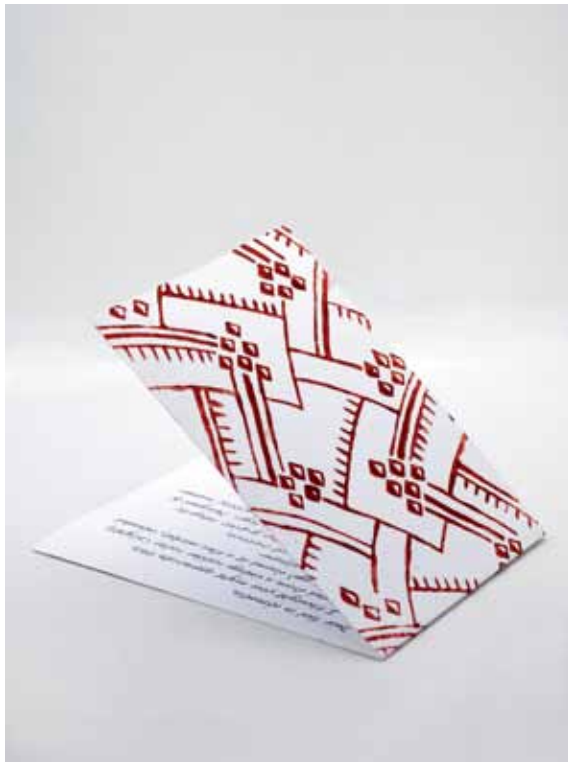

B. Alexandra Szerlip
no title



Judith Tannenbaum
Sunburst for Sol

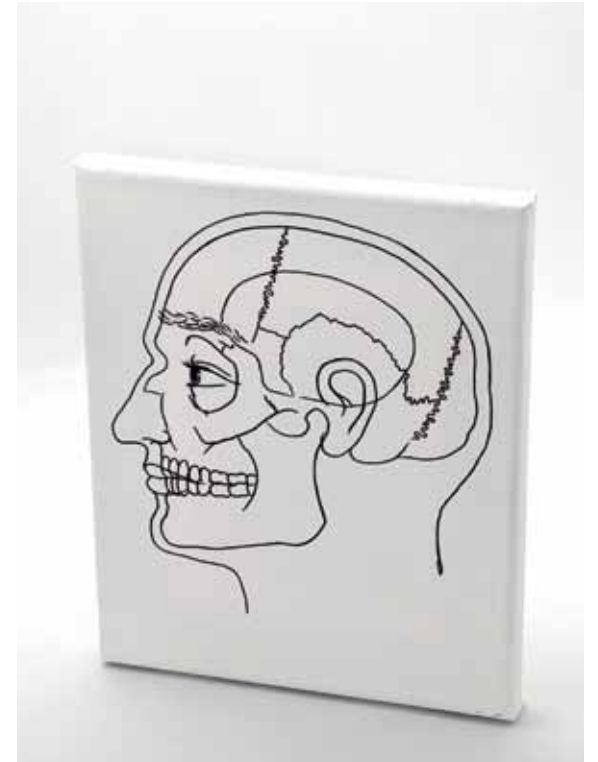

Michael Tarby
no title

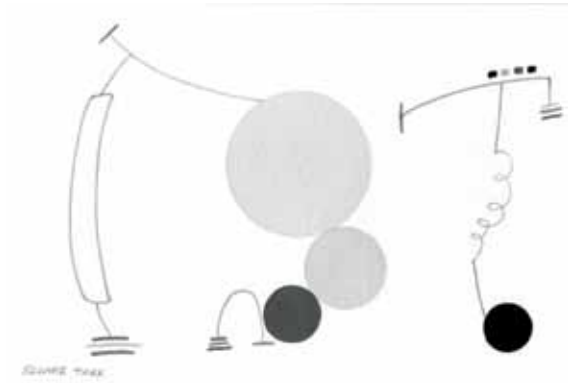

Soonae Tark
Untitled



Caroline Tavelli-Abar
Love and the Freedom to Marry



Christopher W. Thomas
Red, White, Gold



Barbara Amalie Skovmand Thomsen
Love Is A Greyscale Between Two Poles



Brian Taylor
Fake Fur Hat, Jeans, Sneakers, Work Shirt, Jacket



Andreas Templin
Andreas Templin Sings Sol LeWitt

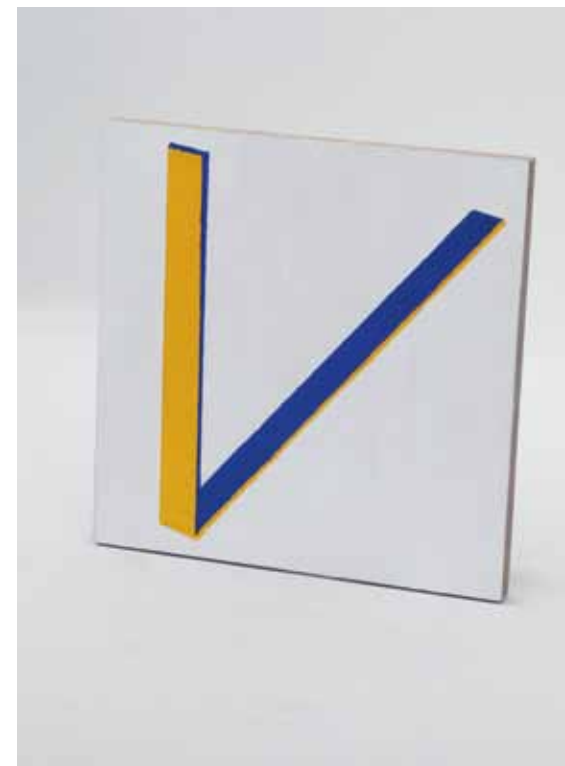

Cassidy Q. Toner
Blue and Yellow Blocks 2



Volker Troche
no title



Fred Truck
Spruce Tree House



Toisha Tucker
Margie



Paul Turano
Direct Film Exercise for Sol LeWitt, (Box with Ink Set, Film)

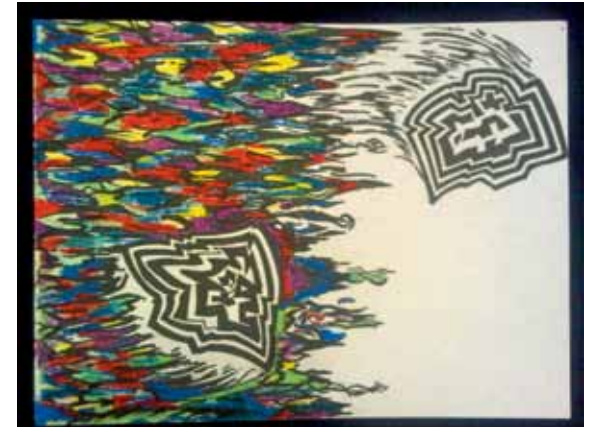

Vanessa Turi
no title



Florin Tudor & Mona Vatamanu
Chalk



Berkay Tuncay
Gift To LeWitt

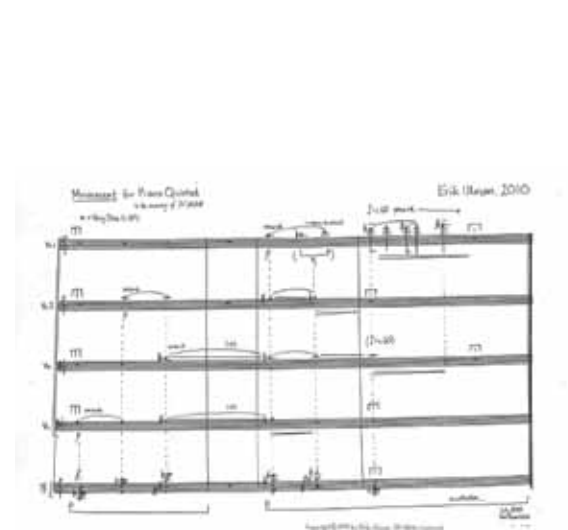

Erik Ulman
Movement



Unglee
Greeting Cards



University of Georgia
no title

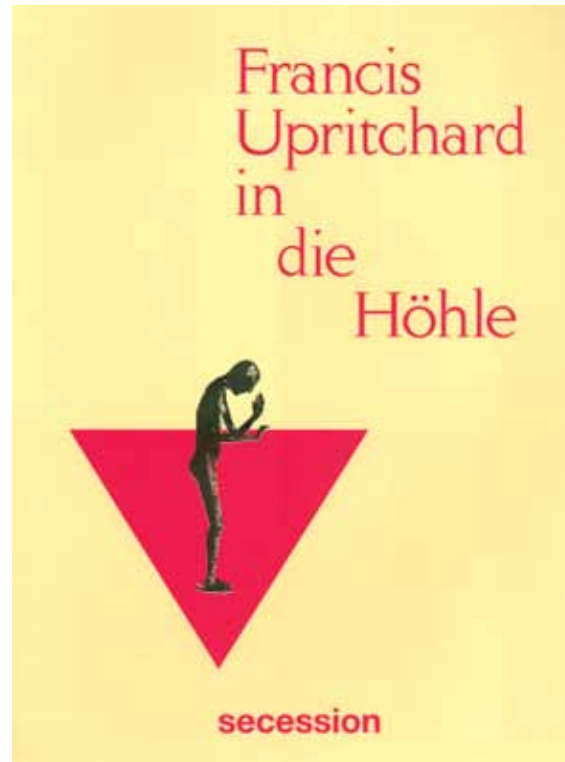

Francis Upritchard
In die Hohle



Clement Valla
Sol LeWitt + Mechanical Turk



Kelly VanderHaeghen
no title

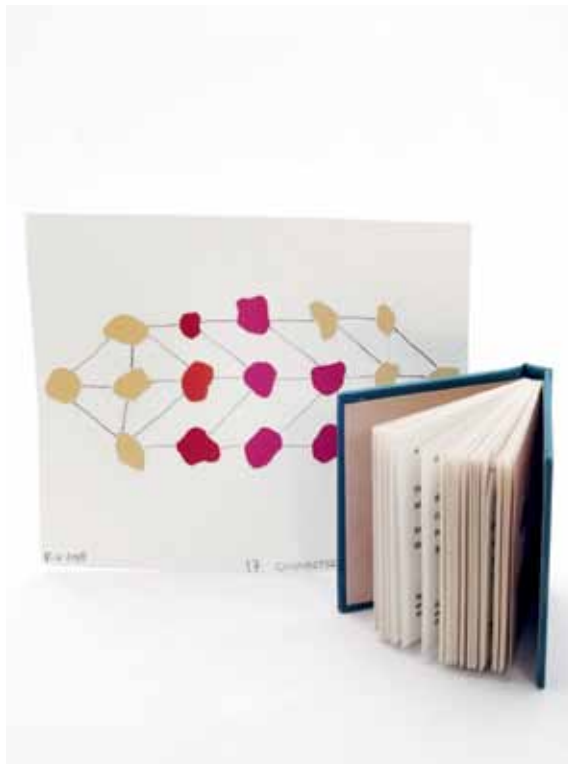

Rachel Urkowitz
17 Connected Blobs for S.L.

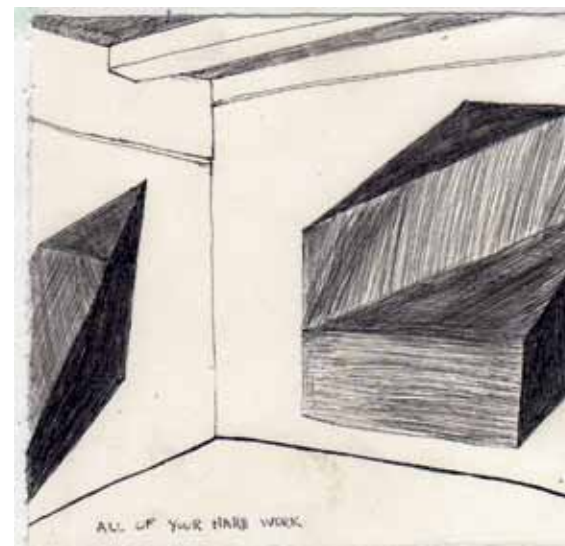

Gabriela Vainsencher
All of Your Hard Work



Jose Velazco
An Interruption

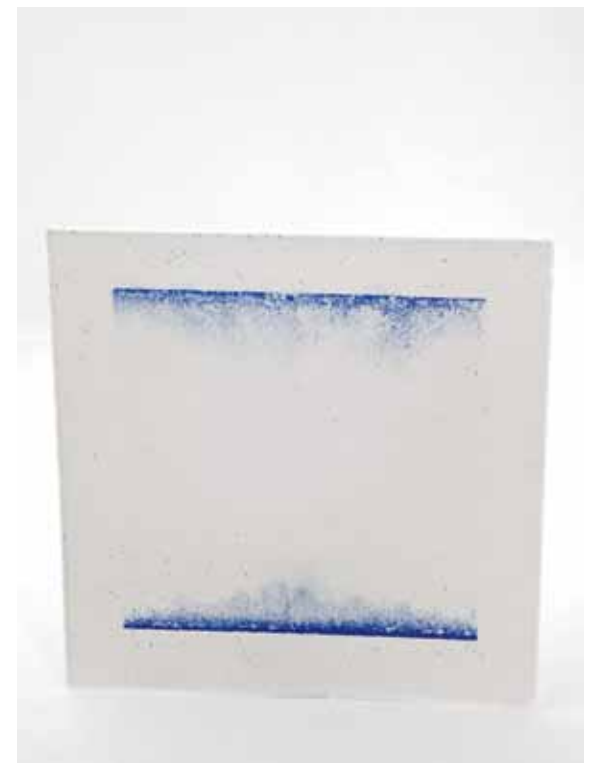

August Ventimiglia
no title



Constance Vepstas
Fantasy Face #2 Waiting

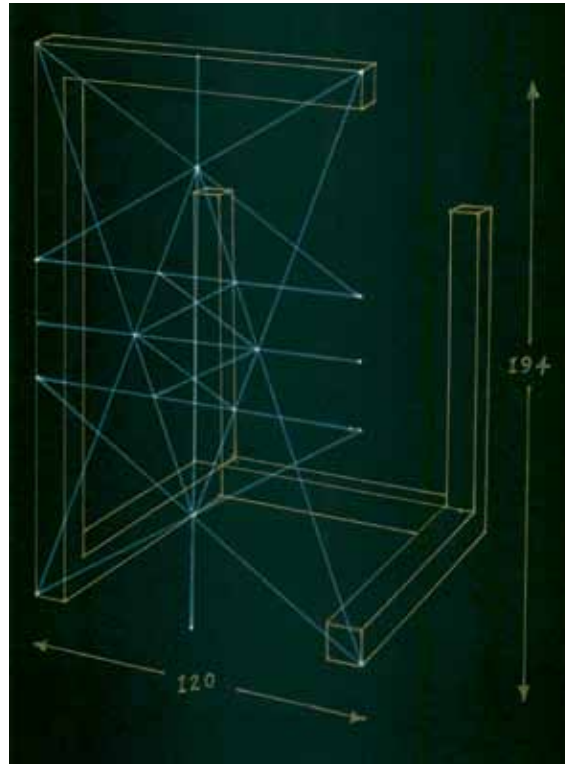

Matthew Verdon
Golden LeWitt



Anton Vidokle & Julieta Aranda
Popular Geometries



Alejandra Villasmil
Stack



Marian Verhaeghe
no title

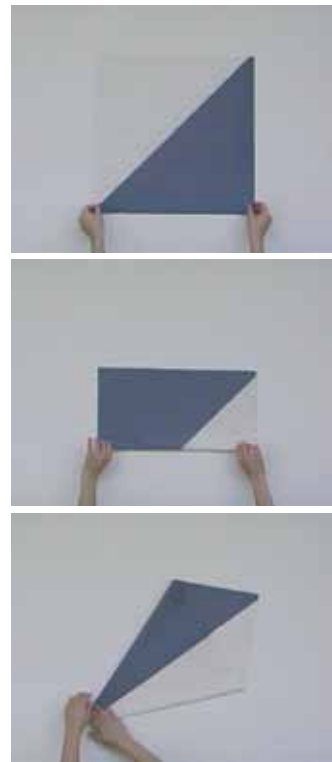

Stefanie Victor
Turns Folds Differences



Niels Vis
Incomplete Open Cube



Francesca Vivenza
From C to C without Sol



Nicole Vogelzang
Velvet Monkey



Don Voisine
Tesseract



Julia Wagner
Cube (for Sol)



Margin of error (An Exchange with Sol LeWitt). 2010. This is an unlimited/unrestricted 'instructional' work owned by whoever comes across it.

The Work

44 copy paper in landscape format is rolled up to make a cylinder whose diameter is determined by the two short edges of the copy paper meeting.

Instruction

Rolling one sheet at a time, add paper to the previous sheet (this repeat action contributing to the growth of the cylinder's diameter).

This repeat rolling action continues until the two short edges of the paper meet determining the cylinder's final diameter (fix in place with double-sided tape).

The pragmatic and mechanical nature of the work though simple, does need to be executed with sensitivity and precision. However, this said, it is to be expected that there will be a human touch and individual tolerance in evidence and that nuance and incident will emerge. Perhaps it is this 'margin of error' between an idea, and its realization, that is the location for what we call art and the poetic.

Walker Hill
Margin of Error (an Exchange with Sol LeWitt)



Wiebke Maria Wachmann
Moon



Johan Waerndt
12304 LINES

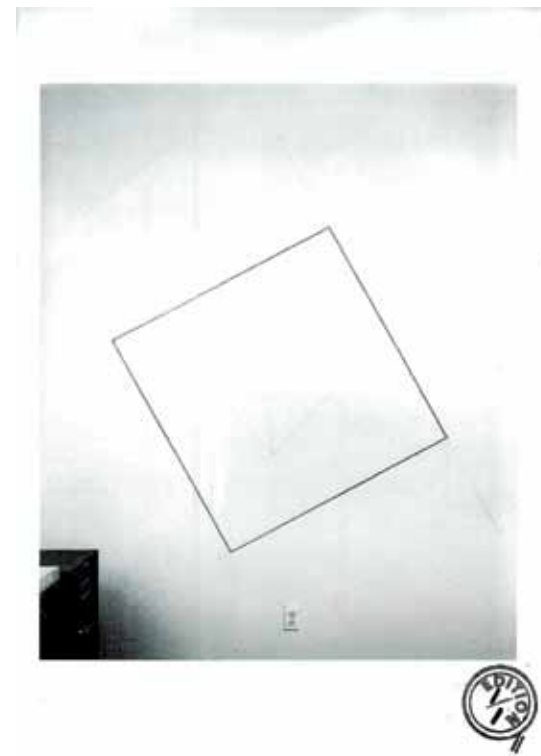

Maria Walls
Wall Drawing # 232



Matt Wardell
Calder is to Babies as LeWitt is to Cats (for Sol)



Christopher Wawrinofsky
Untitled



Jack Wax
Blivet



Michelle Weinberg
Flower Box



Anne Rittany Welling
And Then There Was...



Georg Weckwerth & Sabine Groschup
no title



Joshua Caleb Weibley
"Many Hands..." (Working Title)



Rachel Perry Welty
Constellation #185 for Sol LeWitt



Pwezy Wezy
Loopy-Doopy



Johnny Wheeldon
no title



Sarah Whicker
Luuc Brans



Nancy White
no title



Gail D. Whitter
My Colouring Book



Alexis White
Collage July 15th



Brooke White
Boat Brain



Ian Whittlesea
Sol Sans

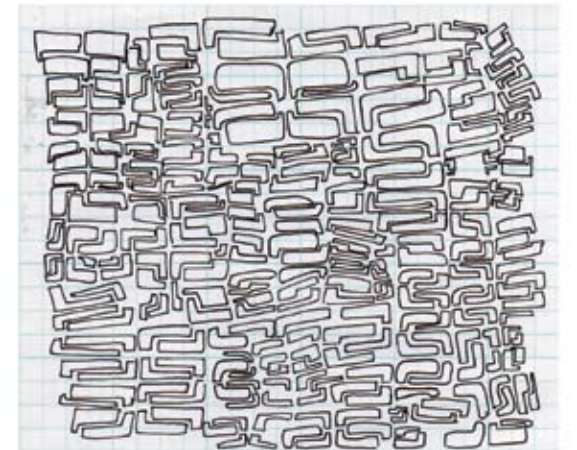

Jeremy Wiles-Young
Sixty-ninepattern



Jim Wilkinson
Untitled



Elyssa Willadsen
After Sol LeWitt, Wall Drawing 610

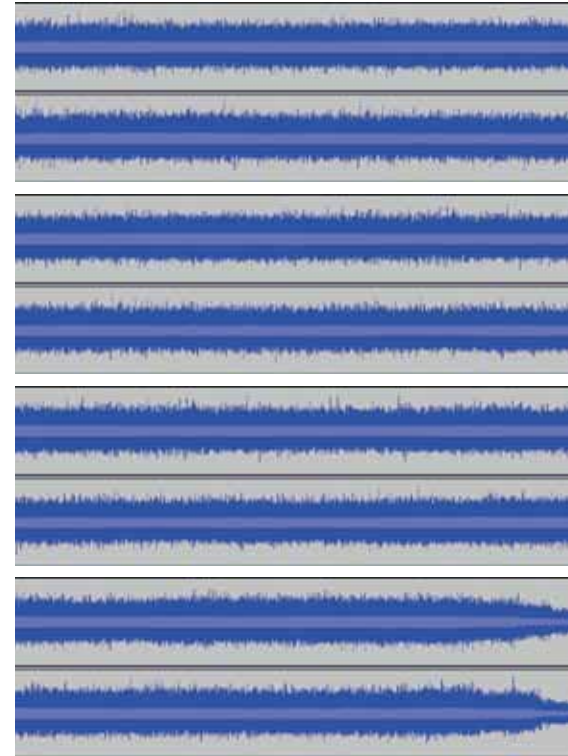

Matthew Wilson
10X Over the Bridge



Josh Winegar
Cars & Road—California



Mandy Williams
Interior 3

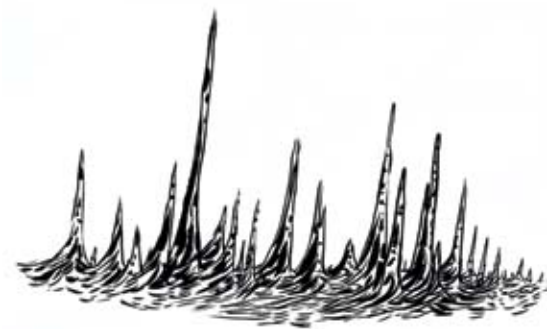

Kate Wilson
Botanical Model City

for Sol LeWitt
1 glissando; 4 sustained tones

a glissando:

- that has a minimal, almost imperceptible slope.
- that starts and ends at the midpoints in time of two sustained tones with the same duration (at most half the duration of the glissando); the first of which ends and the second of which begins in unison with the glissando.
- with a midpoint in pitch that is equidistant to two (other) sustained tones with the same duration (at least three times the duration of the glissando); the first of which ends and the second of which starts at the midpoint in time of the glissando.

The entrances of the sustained tones are preferably accented with percussive attacks that decay slowly and the exits are preferably accented with percussive attacks that are punctuated.

long, clear, not loud.

—michael winter
(february, march, april 2009;
new york city, san francisco, los angeles)

Michael Winter
for Sol LeWitt

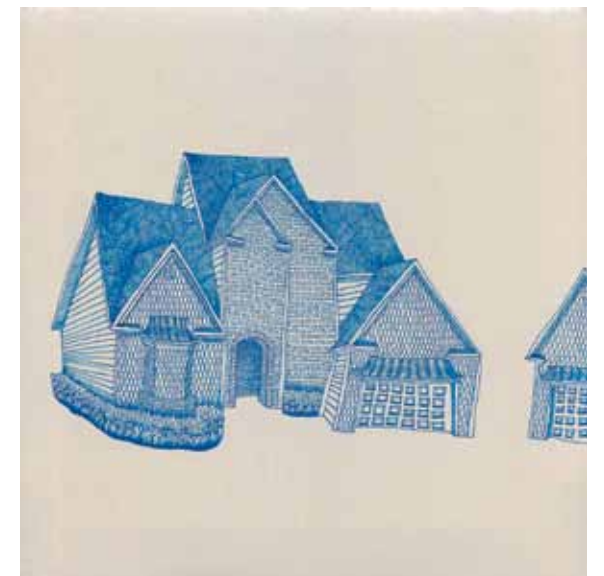

Jessica Wohl
Two Houses One Color



Kathrin Wolkowicz
He Writes the Raincoat a Note What I Own of Him

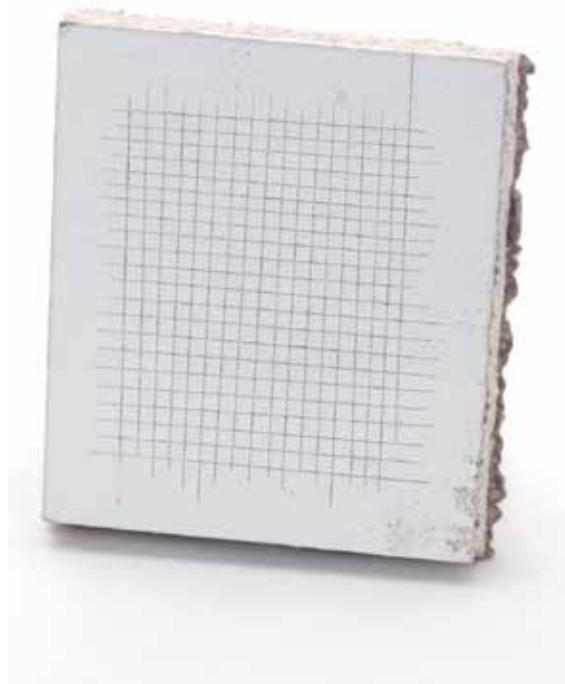

Audra Wolowicz
Cut Lines (for Sol)



Melda Oncu Yildiz
When It's Twelve O'clock



Robert Yoder
Untitled



John MacDuffie Woodburn
A to B



The WRMC Collaborative (Andrew Y. Ames & Alexia Mellor)
Certificate of Citizenship



Plamen Jordanov
Mask

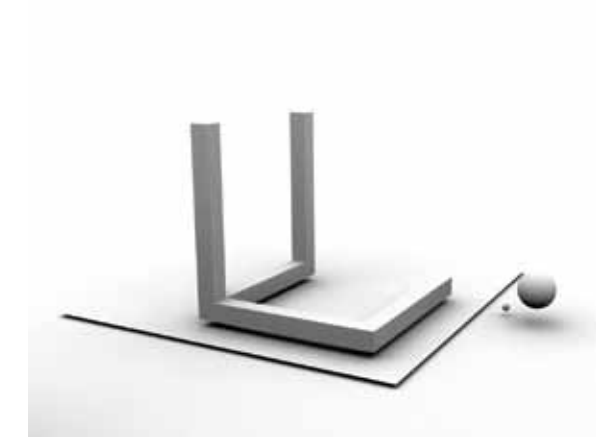

Samuel D. York
Untitled



Gordon Young
no title

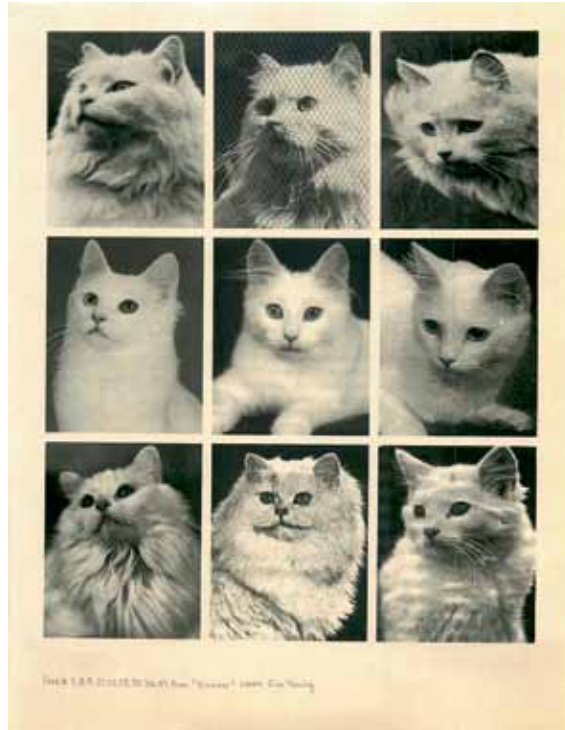

Lisa Young
Clowder

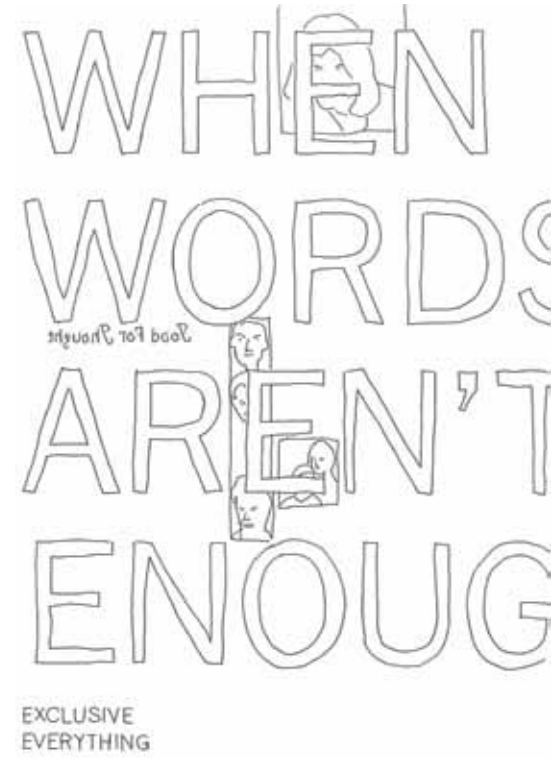

Jody Zellen
When Words Are Not Enough

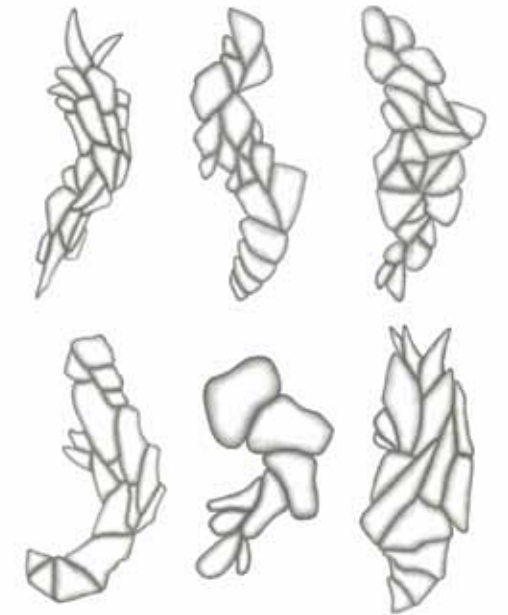

Repetition, Reduction, Accumulation and Arrangement:
Six Variations on a Set Procedure

Therese Zemlin
*Repetition, Reduction, Accumulation, and Arrangement:
Six Variations on a Set Procedure*



Alberto Zanmatti
Ricordo di Sol LeWitt di a.z.

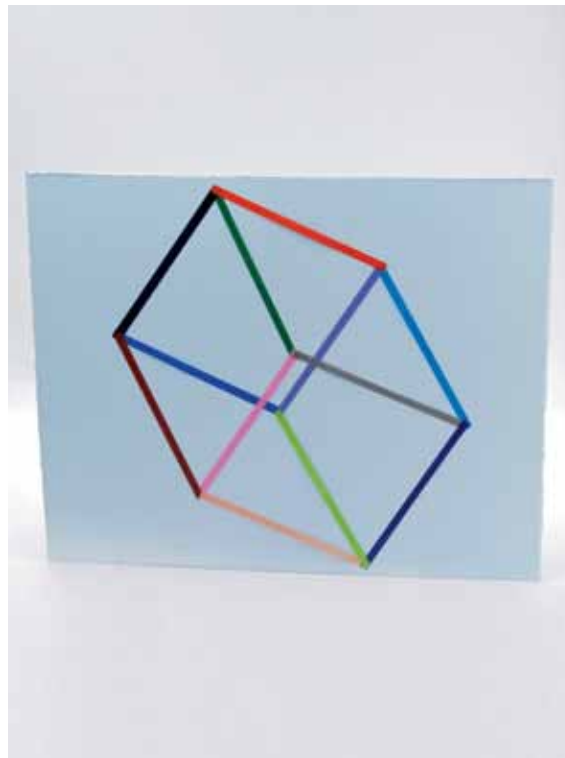

Patricia Zarate
CubeOnBlue

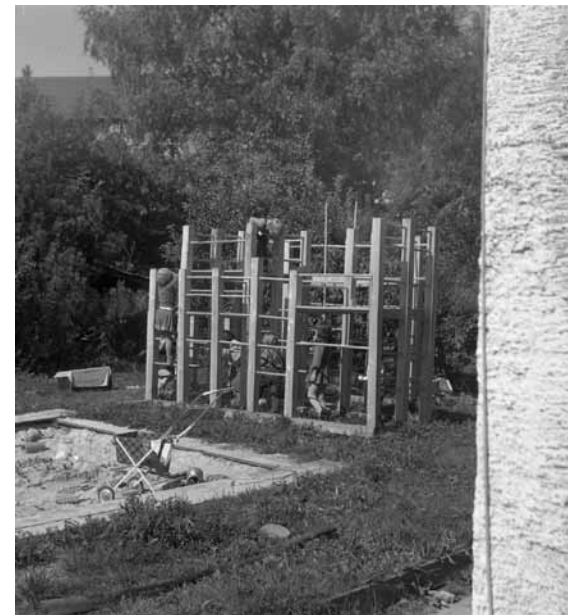

Moira Zoitl
Antiautoritär, Teil 1—Die Ästhetik der Erziehung (Anti-authoritarian, part 1—the aesthetic of education)

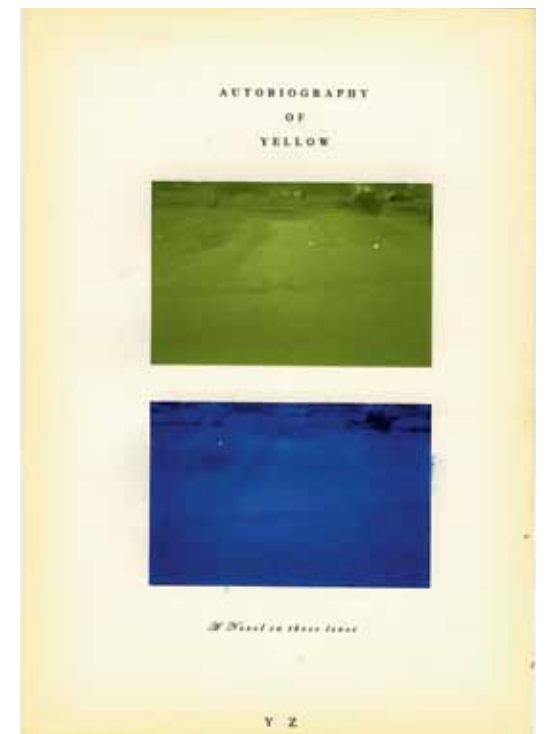

Yonatan Zonszein
Autobiography of Yellow



Chris Zulakis
Abrupt LeWitt



Elizabeth Zvonar
La Futura

AN EXCHANGE WITH SOL LEWITT

DIRECTORY OF ALL CONTRIBUTING ARTISTS

4th Grade Class, Chester
Elementary School
Joshua Abelow
Tisch Abelow
Edith Abeyta
Alejandro T. Acierto
Alexis Acquista
Lisa Adamucci
Isaac Aden
Aeolian Recreational
Boundary Institute
Francine K. Affourtit
June Ahrens
Rachel Ake
Beatriz Albuquerque

Simon Aldridge
Edward Allington
Matt Allison, Shawn Henrie &
Margan Kendall
Can Altay, Jonathan Mosley &
Sophie Warren
Bruce Altschuler
Phil Amrhein
Karl Anderson
Patrick Anderson-McQuoid
Huw Andrews
Anonymous
Anonymouse
Marijke Appelman
Michael Arata

David J. Armacost
Holly Armishaw
Diana Arvanites
Judy Asbury
Shinsuke Aso
Carla Asperilla
Christian Awe
Nina Lola Bachhuber
Fia Backström
Karl Baden
Saebom Bae
Alisha Baird
Steven Ball
Victor Ballesteros
Tiziana Baracchi

Kumasi J. Barnett
Rita Barros
Louise Barry
Amy Bassin
Batman & Batman
David Baumflek
Matthew Bax
Joell Baxter
Matthew Beall
Richie Bearden
Tinka Bechert
Leah Beeferman
Bonnie Begush
Paul Behnke
Mark Crofton Bell
Harvey Bengé
John M. Bennett
Wolfgang Berndt
Charles Beronio
Hilary Berseth
Damiano Bertoli
Katrin Bertram
Gary A. Bibb
Ana Bilankov
Birds Are Nice
Mariella Bisson
Tina Blackburn
Josh Blackwell
Alexandra Blaiotta
Conny Blom
Michael Blum
Alicia Bonilla-Puig
David Borawski
Dmitry Borshch
Nathan Boyer
Daniel Bozhkov
Nell Breyer
Andre Brocatus
Collette Broeders
Jason Brogan
Adam Broomberg & Oliver Chanarin
D. Matthew Brown & Kara Warren
Rae Broyles
Jo Brudenell
James C. Burns
Bibi Calderaro
Luisa Caldwell
Kit Callahan
Javier Cambre
Luis Camnitzer
Arabella Campbell
J. Lynn Campbell
Paulo Campos
Stacey Cann
Henrik Capetillo
Angela Caporaso
Emily Cappa

Kim Carlino
Antonia Carrara
Laura Carton
Rose Marie Castoro
Anibal Catalan
Michael Cavdo
Jonathan Cecil & Yumi Kinoshita
Cedar Tavern Singers
Anna Ceeh
Katherine Cercone
Justin Abbott Chalew
Jenny Zhe Chang
Jessica Chen
Joanne Cheung
Marcy Chevali
Andrea Chiesi
Nathalie Chikhi
Helen Cho
Constantinos Chondros
Warren Chong
Tony Yin Tak Chu
Sarawut Chutiwongpeti
Karen Ciaramella
Gina Clark
Hanna Clark
Seth Cluett
Tony Cokes
Dan Collin
Roberto Comini
Brian Conery
Carol Cooper
Paul Cope
Lynn Corbett
Annette Cords
Alice Cork
Norbert Costin
Costis
Judith Cottrell
Nicholas Aaron Cox
Stephen Cox
Lisa Rybovich Crallé
Holly Crawford
J.J. Cromer
Ken Cushman
Mark Dagley
Lisa Dahl
Soren Dahlggaard
Dana Dal Bo
Kasarian Dane
Dina Danish
Julie Davidow
Kate Davis
Julien de Bock
Tara de la Garza
Caroline De Lannoy
Eric de Leon Zamuco
Lenir de Miranda

Jason Dean & Matthew Nash
Alessio Delli Castelli
Paul Devens
Angela Dittmar
Milos Djordjevic
Edward Dorrian & Mark R Taylor
Pete Driessen
Mario Dsouza
Spartak Dulic
Chris Dupuis
Boris Dworschak
Mary Early
Jeff Eaton & Pablo Helguera
Bryan Eccleshall
Stephan Ehrenhofer
Brandy Eiger
Elizabeth Enders
Rob Engvall
Eosin (Diana Combo)
Catherine Haley Epstein
Cevdet Ereğ
Verónica Rojas Espinosa
Jan Estep
Mary & Matt Even
Arturo Evening
Lee Everett
Bruce Eves
Ellen Hackl Fagan
Jonathan Farber
Annie Farrar
Siobhan Feehan
Lacey Fekishazy
Doris Fend
Teresita Fernandez
Wouter Feyaerts
Susan Field
Kim Fielding, Tom Goddard &
Tiff Oben
Liliana Fijman
Paul Fiore
Kerstin Fischer
Martina Fischer
Andrea Flamini
Harrell Fletcher
Deirdre Fox
Stephanie Francis
Andrea Frank
Lorrie Fredette
Veronica Frenning
Heribert Friedl
Manuela Friedmann
Sven Froekjaer-Jensen
Gerhard Frommel
Leslie Fry
G
Heidrun Gabel-Koepff
Veronica Gabrielse

Ted Gahl
Felipe "Feggo" Galindo
Jenny Galipo
Paul Gallo
Pam Garber & Xenia Pachikov
(Empty Purse)
Max Garrett
Joy Garnett
Sid Garrison
Maria Garton
Till Gathmann
Claire Gavronsky
Moira Geoffrion
Laura F. Gibellini
Jeffrey Gibson
Nuno Gil
James Gilbert
Sarah Giles
Hope Ginsburg
Helidon Gjergji
Cora Jane Glasser
Jessica Alice Gnyp
Matthew Goddard-Jones
Corin Godfrey
Monika Goetz
Max Goldfarb & Allyson Strafella
Charles Goldman
Ricardo Leal Gomes
Cassia Goncalves
Jesse Good
Kathy Goodell
Jenna B. Gotthelf
Elizabeth Gourlay
Terence Gower
David Grainger
Ann E. Grasso
Anna Lena Grau
Chris Griffin
Julio Grinblatt
Ariel M. Gruell
Ufuk Gueray
Colin Guillemet
Karen Gunderson
Zannie Gunn
Anette Haas
Belinda Haikes
Adam Hall
Heidi Hankaniemi
Lucia Harrison
Matthew Harrison
Susan Rowe Harrison
Kelsey Hawk
Daniel Healey
Sarah Hearn
Deborah Hede
Walter Hekster
Lynne Heller
Karen Hennessee
Molly Heron

Elana Herzog
Raul Hidalgo
Sarah Hildebrand
Andrae Hinds
Valerie Hird
Brian Hitselberger
Christopher K. Ho
Laura Holland
Eric Hollender
Karl Holmquist
Honorina
Lindsey Hook
horea
Grier Horner
Lyn Horton
Channa Horwitz
Joelle Hotaling
Sarah Hotchkiss
Iris Hrasovec
Amila Hrustic
Gilbert Hsiao
Barry W. Hughes
Holly Hughes
Nene Humphrey
Cheryl Huntbach
Yarim Hur
Taisha Hutchison
Raymie Iadevaia
Richard Ibghy & Marilou Lemmens
Ida
Mana Ikeda
Irene Imfeld
David Ingenthron
Jeremy Inglis (MODrn)
Kelly Falzone Inouye
Damian Iordanov
Philip Iosca
Matt Jahmer
Jörg Jakoby
Karyn Janowski
Thomas Jarvis
Matthew Jensen
Hye Ram Jeon
Da Young Jeong
Daniel Joglar
Joe Johnson
Kate Johnson
Luke Johnson
Mary Johnson
Jeffrey Cortland Jones
Klaus Jörres
Pierre Juillerat
Timo Kahlen
Robin Kandel
Sun Mee Kang
David Kant
Gregory Kaplowitz
Marina Kassianidou
Marie Kazalia

Kazuko
Zachary Keeting
Mary Kenealy
Sam Keogh
Iordanis Kerenidis &
Piergiorgio Pepe
Nicholas Kersulis
Dean Kessman
Khalid Khan
Angela Kim
Cheonae Kim
Hyo Myoung Kim
Julia Kim
Maritza Ruiz Kim
Maxi Kim
Soo Kim
You Jin Kim
Jamie Kirkland
Marilyn Kirsch
Marsha Klein
Ben Knight
Kathranne Knight
Selin Kocagoncu
Claudia Kochsmeier
Kocot & Hatton
Francine Kohn
Kaisu Koivisto
Valerie Kolakis & Paul Landon
Andreas Kopp
Anna Kordsmeier
Wynn Kramarsky
Frank Krasicki
Walter Kratner
Peter Kreider
Shane Krepakevich
Eric Kressnig
Jeffrey Kriksciun
Judith Kruger
Adeline Kueh
Bessie Kunath
Kathryn Kuntz
John Kupczak
Michael Kuschnir
Sabine Laidig
Corinne Laroche
Paul Laster
John Latour
Louisa Lau
Peter Max Lawrence
Chris Le Page
Monika Lederbauer
Lee Lee
Hui Ling Lee
Claire Lehmann
Rena Leinberger
Eric Leiser
Michael Lent
Craig Leonard
João Leonardo

Dan Levenson
Tan Kwank Liang
Liz Liguori
Mauricio Limon
Lucy Lippard
Rob List
Jung-Hua Liu
Lisa Lok
Mark Lomax
Ron Longsdorf
Alex Lopez
Tom Lovelace
Jonas Lozoraitis
Adam Lucas &
Corydon Cowan Sage
Lauren Luloff
Teodoro Lupo
LustrousChemistry
Euan Macdonald
Tatjana Macic
Alisdair MacRae
Ian MacTilstra
Renée Magaña
Basim Magdy
Moritz Majce
M. Makki
Jessie Mann
Eva Mantell
Tom Marioni
Monika Marklinger
Melissa Marks
Laszlo Marsch
Christina Martinelli
Margherita Marzorati
Jay Masonek
Thelma Mathias
Lauren Matsumoto
Patrick Maxcy
Jackie McAllister
Scott McCarney
Serena McCarroll
Jeni McConnell
Timothy McDowell
Alexandra McGlynn
John McLaughlin
Sarah McMenimen
David McNab & Bryan Eccleshall
Christopher McNulty
Nancy Anne McPhee
Matthew McQuillan
Kathleen McShane
Mary-Anne McTrowe
Beth Megatulski
Meryl Meisler
John Eugene Melecsinsky
Tom Melick
Eric Meltzer
Jason Mena
Astrid Menze

Alejandro Merizalde
Jon Meyer
Jane Chang Mi
Marina Miletic
Bradley Miller
Hye-Ryoung Min
Louisa Minkin
Stephen Mishol
Benjamin Mitchell
Eileen Starr Moderbacher
Jose Molestina
MomenTech
Young Min Moon
Robert C. Morgan
Michael Morrill
Cate Morrison
Judd Morrissey
Leo Morrissey
Nicole Mortiboys
Arezo Moseni
Mariella Mosler
Andy Moxon
Tiki Mulvihill
Ana Hadzi Muratovic
Liz Murfitt
Shea Naer
Yoshi Nakama
Lisa Nankivil
Lisa Nanni
Mary Nash
Cherilyn Naughton
Terry Nauheim
Toony Navok
Lilo Nein
Cristina Neves
Paula Neves
Laura Newman
Chee Wang Ng
Matt Niebuhr
Adam Niklewicz
Justin Nissley
Rose Nolan
Minou Norouzi
Bob Nugent
Kristen Nyce
Miika Nyyssonen
Anne O'Callaghan
Amanda Oliphant
Juan Olvera
Anselm Orasch
Ela Orleans
David Oswald
Yukimi Otagiri
Jurgen Ots
Kjell Otterness
Kenji Ouellet
Adrienne Outlaw
Barbara Assis Pacheco
Scott Page

Cristina Palacios
Kirsten Palz
Salvatore Panatteri
Jared Pappas-Kelley
Lilia Papperini
Sjoerd & Laura Paridaen
Seongmi Park
Roula Partheniou
Chloe Pascal
John Pearson
Adria Pecora
Rachel Peddersen
Haavard Pedersen
Leemour Pelli
Jenny Perlin
Jaime Permuth
Tessa Perutz
Eva Petric
Alan Phelan
Hattie Phillips
Noah Phillips
Andrea Pinheiro
Nikholis R. Planck
Mel Prest
Franklin Preston
James Prez
Dustin M. Price
David Proconiar
Sejma Prodanovic
Michael Raaum
Ross Racine
Nora Raggio
Jared L. Ragland
Mischa Rakier
Paul Ramirez Jonas
Debra Ramsay
Trish Ramsay
Sal Randolph
Victor Raphael
Ray Rapp
Rashanna Rashied-Walker
Lisi Raskin
Eugenia Raskopoulos
Birgit Rathsmann
Beverly Rautenberg
Lucy Raven
Chris Rawcliffe
Andrea Ray
Ben Raynor
Xavier Rayuela
Gail Rebhan
Sandra Rechico
Susan Reedy
Andrea Dasha Reich
Arnold Reinisch
David Rhodes
Vel Riberto
Angelo Ricciardi
Frances Richard & Shelly Silver (and

in absentia, Sol LeWitt & Eva Hesse)	Champe Smith	Constance Vepstas
Lynn Richardson	Damon Smith	Matthew Verdon
Josué Rivera	Lucas Soi	Marian Verhaeghe
Dai Roberts	Joel Soliven	Stefanie Victor
Veronica Roberts	Ted Somogyi	Anton Vidokle & Julieta Aranda
steve roden	Eve Sonneman	Alejandra Villasmil
Ana João Romana	Natalie Sorenson	Niels Vis
Vincent Romaniello	Manuel Sosa	Francesca Vivenza
Taney Roniger	Milena Sosa	Nicole Vogelzang
Brian Rosa	Edra Soto	Don Voisine
Matthew Rose	Mariangeles Soto-Diaz	Wiebke Maria Wachmann
Rhoda Rosenberg	Joyce Speechley	Johan Waerndt
Carol Simon Rosenblatt	Deanna Sperrazza	Julia Wagner
Barbara Rosengarth	Janet Stafford	WalkerHill
Lisa K. Rosenstein	Malin Ståhl	Maria Walls
Jessica Deane Rosner	Wim Starkenburg	Matt Wardell
Marie Roux	Carol Starr	Christopher Wawrinofsky
Philippe F. Roux	Roderick Steel	Jack Wax
Andrea Rubio	Oona Stern	Georg Weckwerth & Sabine Groschup
Donna Ruff	Sam Still	Joshua Caleb Weibley
Judy Rushin	Nico Stock	Michelle Weinberg
Carmelle Safdie	Tim Stoelting	Anne Rittany Welling
Veronica Sahagun	Yuri Stone	Rachel Perry Welty
Agatha Salvatierra	Lars Strandh	Pwezzy Wezzy
Hope Sandrow	Ray Stratton	Johnny Wheeldon
Raphy Sarkissian	Holly Streekstra	Sarah Whicker
Rui Sasaki	Rebeca Stumm	Alexis White
Antje Sauer	Diana Sugar	Brooke White
Ron Saunders	Terry Surjan	Nancy White
Claudia Sbrissa	B. Alexandra Szerlip	Gail D. Whitter
David Schafer	Kelvin Tan Ke Yun	Ian Whittlesea
James Schaffer	Gloria Tanchelev	Jeremy Wiles-Young
Karen Schifano	Judith Tannenbaum	Jim Wilkinson
Mary Schiliro	Michael Tarby	Elyssa Willadsen
Sarah Schlenker	Soonae Tark	Mandy Williams
Cecilia Schmidt	Caroline Tavelli-Abar	Kate Wilson
Marcia Scott	Brian Taylor	Matthew Wilson
Ginger Scott	Andreas Templin	Josh Winegar
Scott & Skúta	Christopher W. Thomas	Michael Winter
Antonio Serna	Barbara Amalie Skovmand Thomsen	Jessica Wohl
Nina Servizzi	Cassidy Q. Toner	Kathrin Wolkowicz
Samuel Sfirri	Volker Troche	Audra Wolowiec
Rose Shakinovsky	Fred Truck	John MacDuffie Woodburn
Dee Shapiro	Toisha Tucker	The WRMC Collaborative (Alexia Mellor & Andrew Y. Ames)
Yi Sheng	Florin Tudor & Mona Vatamanu	Melda Oncu Yildiz
Jieun Shin	Berkay Tuncay	Robert Yoder
Lisa Sigal	Paul Turano	Plamen Yordanov
Suzanne Silver	Vanessa Turi	Samuel D. York
Peter Simensky	Erik Ulman	Gordon Young
Linda Simmel	Unglee	Lisa Young
Eric Simon	University of Georgia	Alberto Zanmatti
Judith Simonian	Francis Upritchard	Patricia Zarate
Nina Slejko	Rachel Urkowitz	Jody Zellen
Nataliya Slinko	Gabriela Vainsencher	Therese Zemlin
Louise P. Sloane	Clement Valla	Moira Zoitl
Ben Sloat	Kelly VanderHaeghen	Yonatan Zonszein
Susannah Slocum	Jose Velazco	Chris Zulakis
Ana Sluga	August Ventimiglia	Elizabeth Zvonar

